

# MANDÍK<sup>®</sup>

## FIRE DAMPER

## FDMA



These technical specifications state a row of manufactured sizes and models of fire dampers (further only dampers) FDMA. It is valid for production, designing, ordering, delivery, assembly and operation.

**I. CONTENT**

<b>II. GENERAL INFORMATION</b>	<b>3</b>
1. Description.....	3
2. Design.....	4
3. Dimensions, weights and effective area.....	14
4. Placement and Assembly .....	22
5. Statement of installations .....	24
6. Suspension system.....	41
<b>III. TECHNICAL DATA</b>	<b>45</b>
7. Pressure loss.....	45
8. Coefficient of local pressure loss.....	46
9. Noise data.....	47
<b>IV. MATERIAL, FINISHING</b>	<b>49</b>
10. Material.....	49
<b>V. INSPECTION, TESTING</b>	<b>50</b>
11. Inspection, testing.....	50
<b>VI. TRANSPORTATION AND STORAGE</b>	<b>50</b>
12. Logistic terms.....	50
<b>VII. ASSEMBLY, ATTENDANCE, MAINTENANCE AND REVISIONS</b>	<b>50</b>
13. Assembly.....	50
14. Entry into service and revisions.....	51
15. Spare parts.....	51
16. Restore function of actuating mechanism after fuses initiation.....	51
<b>VIII. ORDERING INFORMATION</b>	<b>52</b>
17. Ordering key.....	52
<b>IX. PRODUCT DATA</b>	<b>53</b>
18. Data label.....	53

## II. GENERAL INFORMATION

### 1. Description

- 1.1. Fire dampers are shutters in ducts of air-conditioning devices that prevent spreading the fire and combustion products from one fire segment to the other one by means of closing the duct in the points of fire separating constructions.

Dampers blade automatically closes air duct using a shutting spring or an actuating mechanism back spring. The shutting spring is started by releasing an initiation lever. The impulse for releasing the lever can be either a manual one, a thermal one or an electromagnetic one. The back spring of the actuating mechanism is started when the thermoelectrical starting mechanism BAT is activated, when a reset button on BAT is pushed or when a power supply of the actuating mechanism is stopped.

The damper is sealed with a silicon packing against smoke penetration after closing the blade. At the same time, the damper blade is bedded in a material which enlarges its capacity and air proofs the air duct.

Dampers have two inspection holes.

Fig. 1 FDMA with actuating mechanism



Fig. 2 FDMA with mechanical control



- 1.2. Damper characteristics

- CE certified acc. to EN 15650
- Tested in accordance with EN 1366-2
- Classified acc. to EN 13501-3+A1
- Fire resistance EIS 120, EIS 90
- External Casing leakage class ATC 3 (old marking "C"), Internal leakage class 2 acc. to EN 1751
- Cycling test in class C 10000 acc. to EN 15650
- Corrosion resistant acc. to EN 15650
- ES Certificate of conformity No. [1391-CPR-XXXX/XXXX](#)
- Declaration of Performance No. [PM/FDMA/01/XX/X](#)
- Hygienic assessment of fire dampers - Report No. [1.6/pos/19/19b](#)

- 1.3. Working conditions

Right damper function is secured under the following conditions:

- a) Maximum air circulation speed: 12 m/s  
Maximum pressure difference: 1200 Pa
- b) The air circulation in the whole damper section must be secured as steady on whole surface.

Operation of the dampers does not depend on the direction of air circulation. The dampers can be located in an arbitrary position.

Dampers are suitable for systems without abrasive, chemical and adhesive particles.

Dampers are designed for macroclimatic areas with mild climate according to EN IEC 60 721-3-3 ed.2., class 3K22. (Environment 3K22 is typically protected place with regulated temperature)

Temperature in the place of installation is permitted to range from -30°C to +50°C.

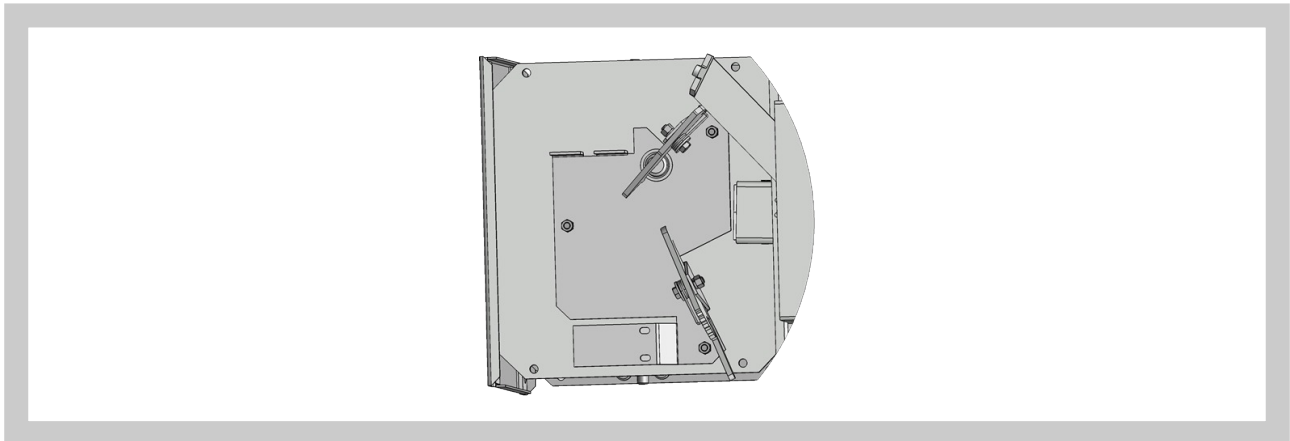
**2. Design**

**2.1. Design with mechanical control**

**Design .01**

Design with mechanical control with a thermal protective fuse which actuates the shutting device after the nominal start temperature 72°C has been reached. Automatic initiation of the shutting device is not activated if the temperature does not exceed 70°C. In case that other start temperatures are required, thermal fuses with nominal start temperature +104°C or +147°C can be supplied (this requirement must be specified in the order).

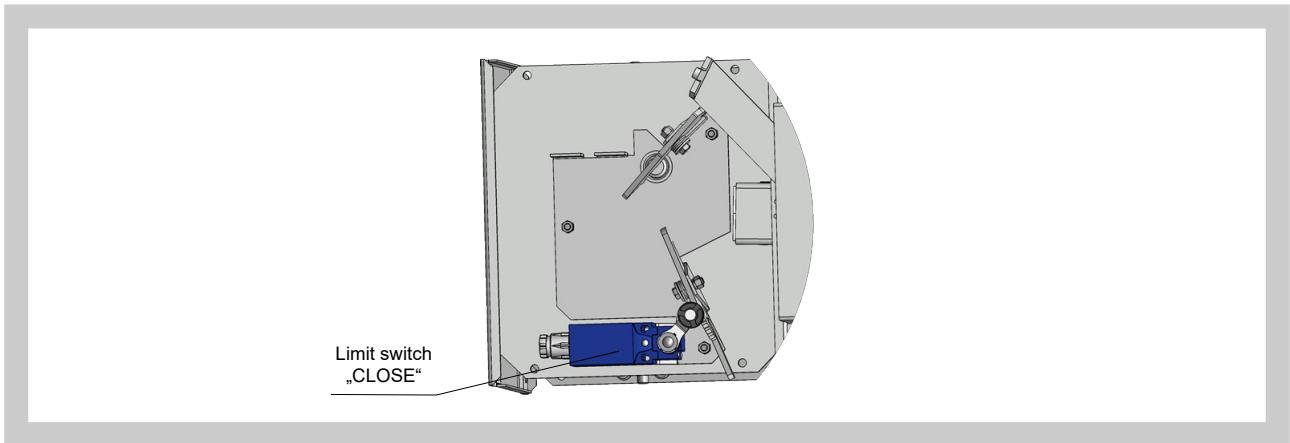
**Fig. 3 Design .01 - design with mechanical control**



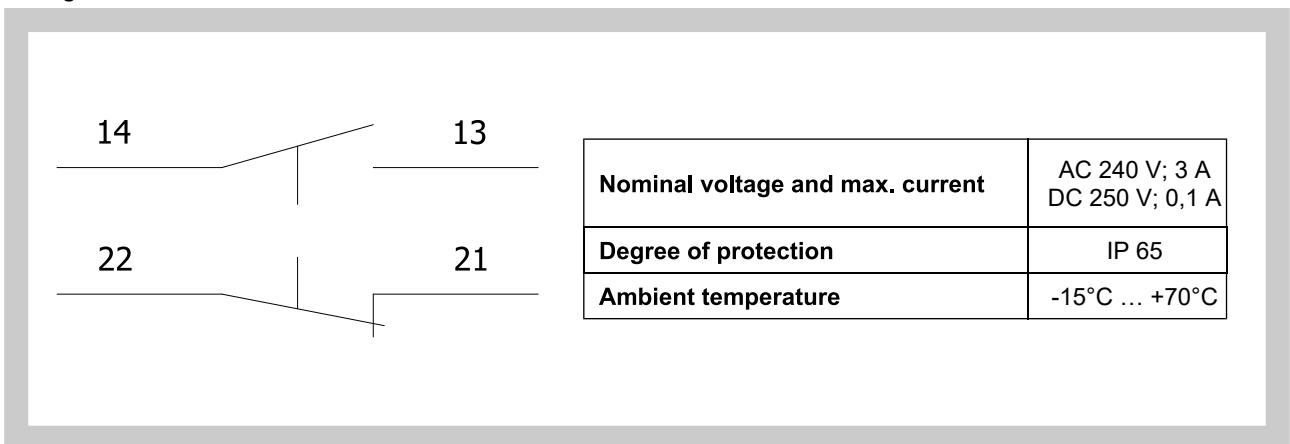
**Design .11**

Design .01 with mechanical control can be complemented with a limit switch signalling of the damper blade position "CLOSED".

**Fig. 4 Design .11 - design with mechanical control and limit switch "CLOSE"**



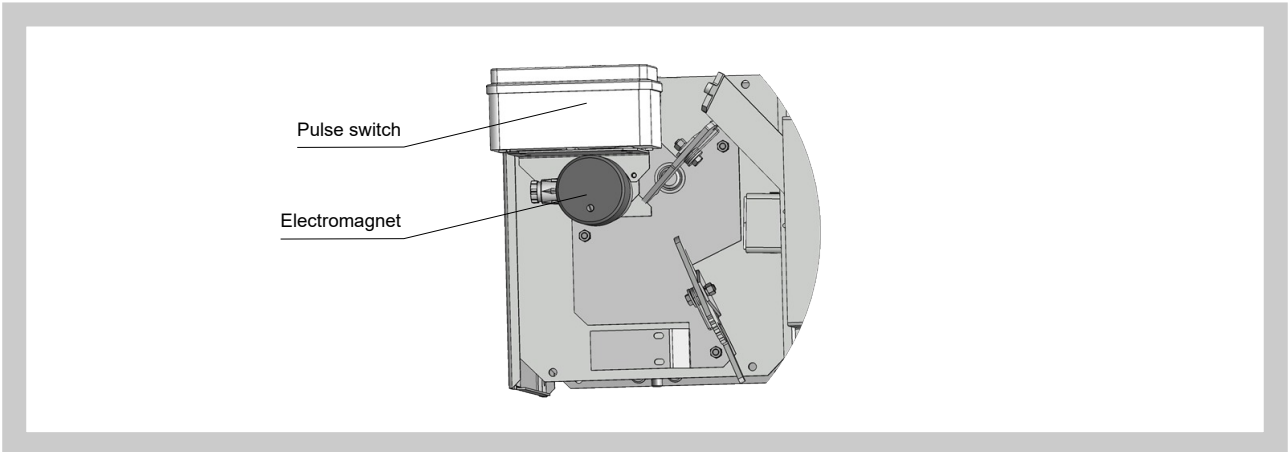
**Fig. 5 Limit switch XCKN2118G-11**



**Design .20 and .21**

Design .01 with mechanical control can be complemented with initiation by means of an electromagnet (solenoid). The voltage of the electromagnet (solenoid) can be AC 230V, AC/DC 24V. By voltage AC 230 V is damper equipped by electromagnet EM230. By voltage AC/DC 24 V is damper equipped by electromagnet EM230 with pre-pulse switch SIEM24. SEIM24 activates the electromagnet after capacitor charge witch is placed inside of SIEM24. It takes about 10 sec. Charging time depends on the current supply. For reliable operation is necessary connect to electromagnet or pre-pulse switch appropriate supply for 20 to 30 sec. After activation of electromagnet is released initiation lever and damper is closed. After activation is initiation lever released. If is damper set up in position "OPEN" is necessary unlock initiation lever by pulling of electromagnet core.

**Fig. 6 Design .20, .21 - design with mechanical control and electromagnet (solenoid)**



**Fig. 7 Electromagnet EM230**

<b>Nominal voltage</b>	AC 230 V / 50 Hz
<b>Attraction current</b>	1,2 A
<b>Degree of protection</b>	IP 40
<b>Ambient temperature</b>	-10°C ... +40°C
<b>Connection</b>	cable 1m, 3x0,75mm <sup>2</sup>

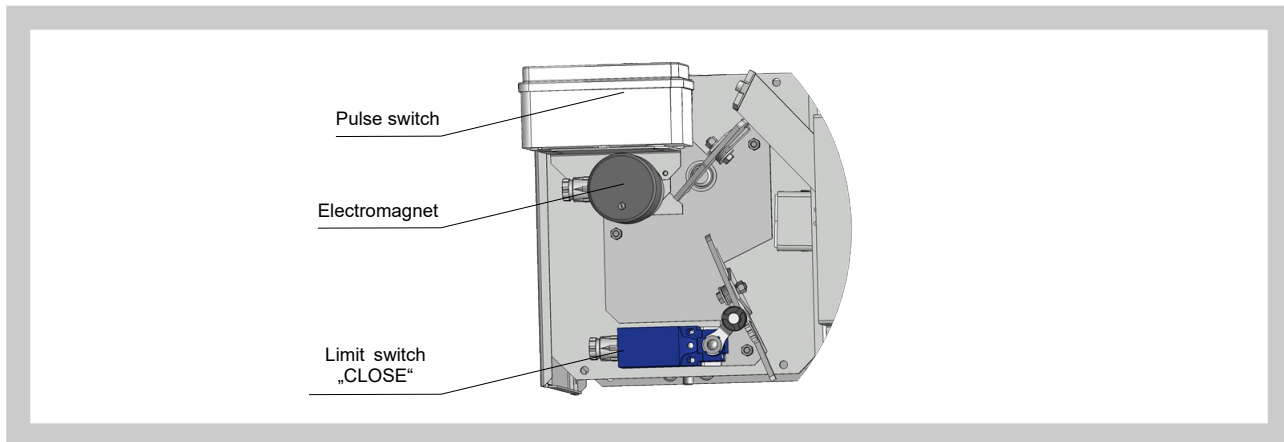
**Fig. 8 Electromagnet EM230 with pulse switch SIEM24**

<b>Nominal voltage</b>	AC 24 V / 50 Hz DC 24 V
<b>Attraction current</b>	1 A
<b>Degree of protection</b>	IP 40
<b>Ambient temperature</b>	-10°C ... +40°C
<b>Switching frequency</b>	max. 1x per minute
<b>Connection</b>	cable 1m, 3x0,75mm <sup>2</sup>

**Design .23 and .24**

Design .20 or .21 with mechanical control and electromagnet can be complemented with limit switch signalling of the damper blade position "CLOSE".

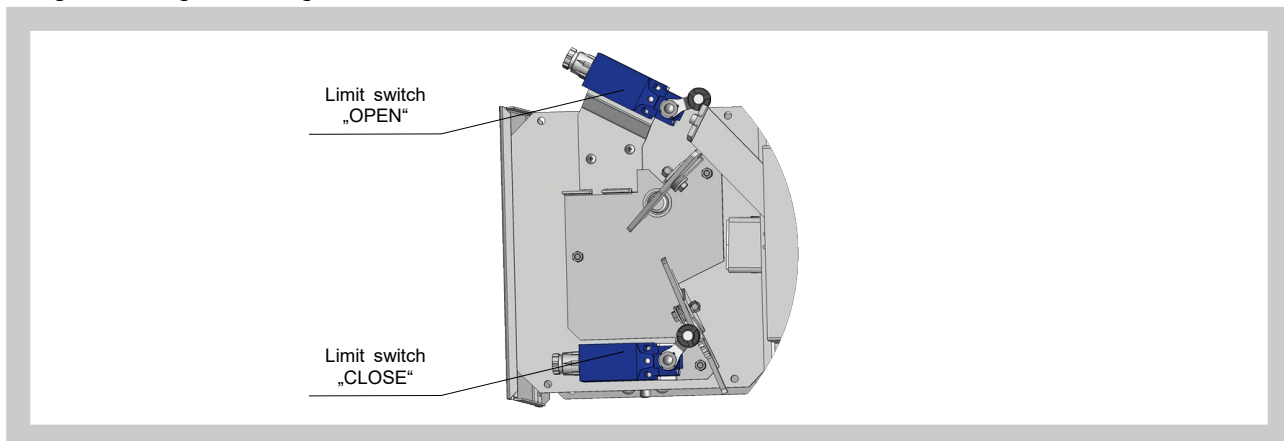
**Fig. 9 Design .23, .24 - design with mechanical control, electromagnet (solenoid) and limit switch**



**Design .80**

Design .11 can be complemented with a terminal switch signalling of the damper blade position "OPEN".

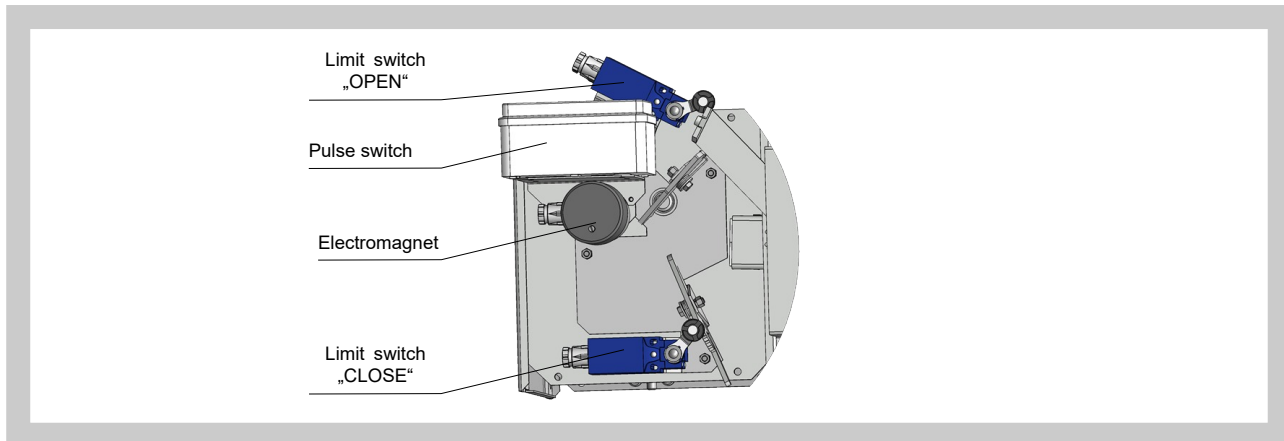
**Fig. 10 Design .80 - design with mechanical control and limit switches „OPEN“, „CLOSE“**



**Design .82, .83**

Design .23, or .24 can be complemented with a terminal switch signalling of the damper blade position "OPEN".

**Fig. 11 Design .82, .83 - design with mechanical control, electromagnet (solenoid) and limit switches**



**Product designed into the Zone 2 (designs .30, .33, .85)**

Product is designed to the Zone 2 with mechanical actuating mechanism and fusible link, electromagnetic initiator (AC 230V) and auxiliary with end-switches (signalling the position of the blade "Open" or/and "Close"). Such designs are the same as the designs .23, .24 and .83 and they are adapted to fulfill the requirements of the usage in the Non- explosive environment.

2.2. Design with actuating mechanism

**Design .40, .50**

The damper are equipped by Belimo actuators with spring return and thermoelectric activation device of BFL, BFN or BF depending on the damper size (further mentioned as „actuators“). After being connected to power supply AC/DC 24V or 230V, the actuating mechanism displaces the damper blade into operation position "OPEN" and at the same time it pre-stretches its back spring. When the actuating mechanism is under voltage, the damper blade is in the position "OPEN" and the back spring is pre-stretched. Time needed for full opening of the flap blade from the position "CLOSED" to the position "OPEN" is maximum 120 sec. If the actuating power supply is cut off (due to loss of supply voltage, or pushing the reset button on the thermoelectrical starting mechanism BAT), the back spring displaces the damper blade into the breakdown position "CLOSED". The time of displacing the blade from the position "OPEN" to the position "CLOSED" takes maximum 20 sec. In case that the power supply is restored again (the blade can be in any position), the actuating mechanism starts to re-displace the damper blade into the position "OPEN". A thermoelectrical starting mechanism BAT, which contains two thermal fuses Tf1 and Tf2, is a part of the actuating mechanism. These fuses are activated when temperature +72°C has been exceeded (the fuse Tf1 when the temperature around the damper and the fuses Tf2 when the temperature inside the air-conditioning piping has been exceeded). After the thermal fuse Tf1 or Tf2 has been activated, the power supply is permanently and irreversibly cut off and the actuating mechanism, by means of the pre-stretched spring, displaces the damper blade into the breakdown position "CLOSED".

Signalisation of damper blade position "OPEN" a "CLOSE" is provided by two limit switches.

Fig. 12 Design .40, .50

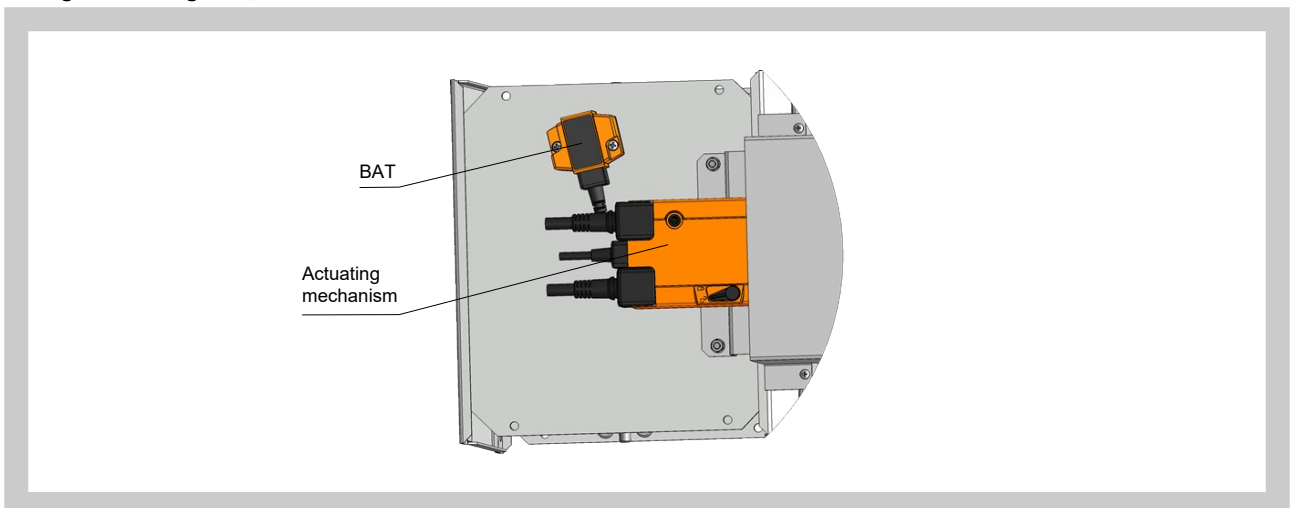


Fig. 13 Actuating mechanism BELIMO BFL (BFN) 230-T

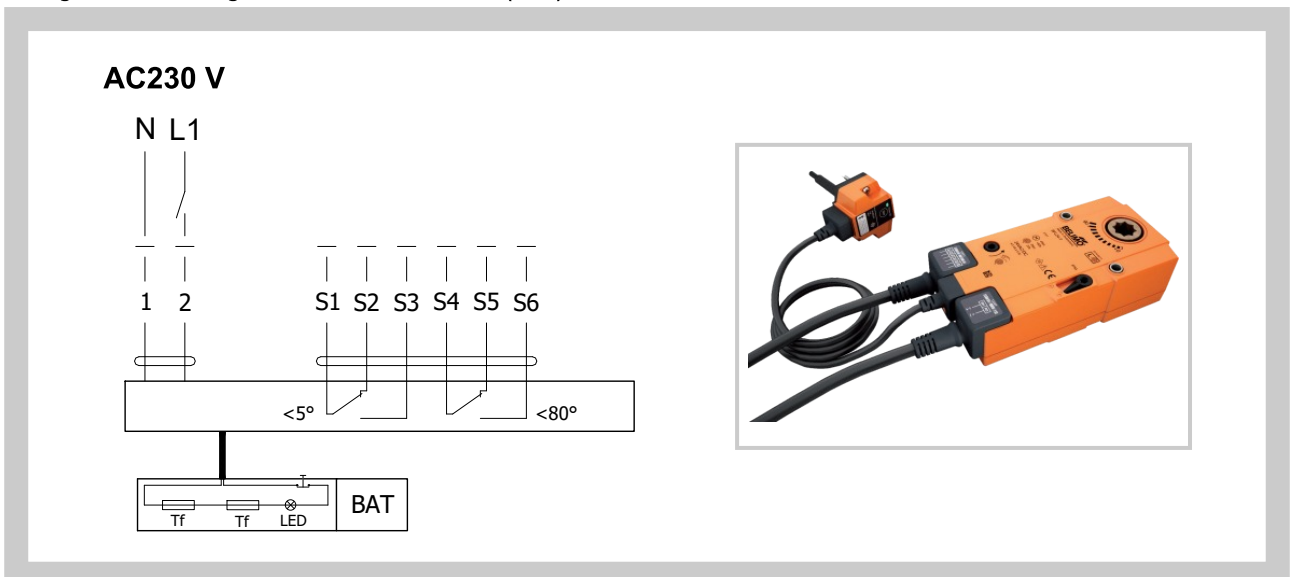
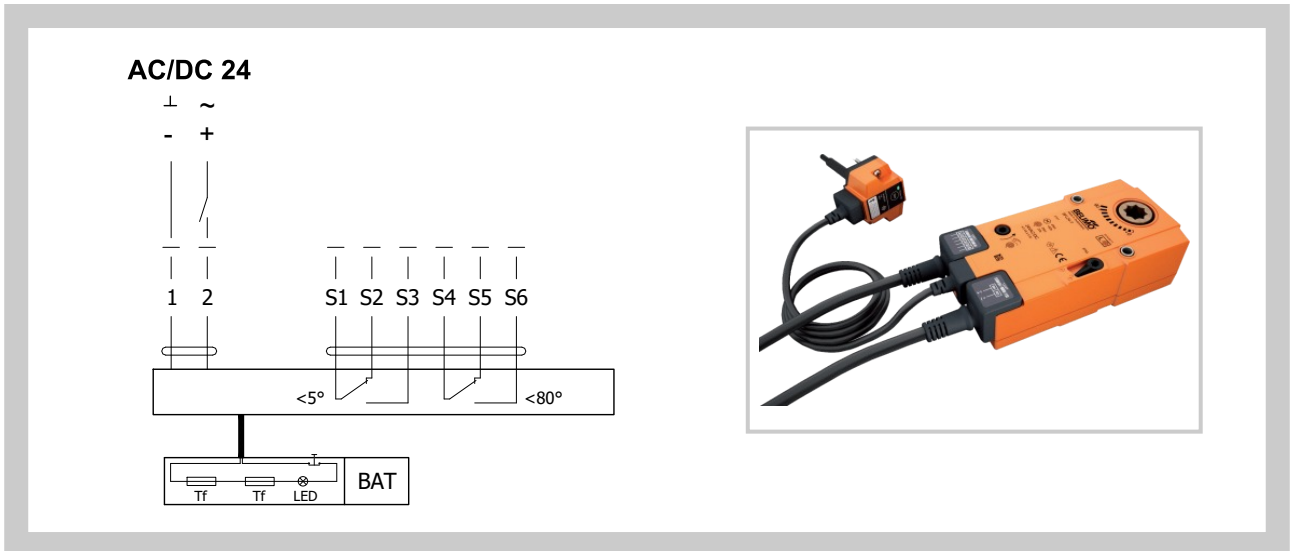




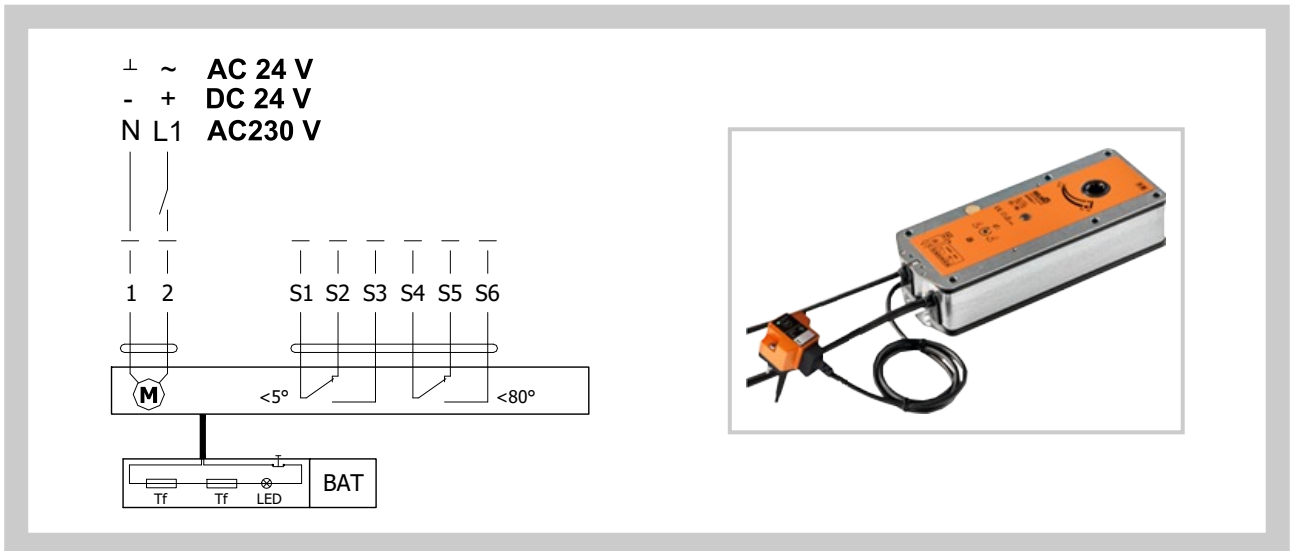
Fig. 14 Actuating mechanism BELIMO BFL (BFN) 24-T(-ST)



Tab. 2.2.1. Actuating mechanism BELIMO BFL24-T(-ST), BFN 24-T(-ST), BFL 230-T a BFN 230-T

Actuating mechanism BELIMO	BFL, BFN 230-T	BFL, BFN 24-T(-ST)
Nominal voltage	AC 230 V 50/60 Hz	AC 24 V 50/60 Hz DC 24 V
Power consumption - motoring - holding	3,5/5 W 1,1/2,1 W	2,5/4 W 0,8/1,4 W
Dimensioning	6,5/10 VA (I <sub>max</sub> 4 A @ 5 ms)	4/6 VA (I <sub>max</sub> 8,3 A @ 5 ms)
Protection class	II	III
Degree of protection	IP 54	
Running time - motor - spring return	<60 s ~ 20 s	
Ambient temperature - normal duty - safety duty - non-operating temperature	- 30°C ... +55°C The safe position will be attained up to max. +75°C - 40°C ... +55°C	
Connecting - motor - auxiliary switch	cable 1 m, 2 x 0,75 mm <sup>2</sup> (BFL/BFN 24-T(-ST)) with 3-pin plug-in connectors cable 1 m, 6 x 0,75 mm <sup>2</sup> (BFL/BFN 24-T(-ST)) with 6-pin plug-in connectors	
Thermal trips	duct outside temperature +72°C duct inside temperature +72°C	

Fig. 15 Actuating mechanism BELIMO BF 230-TN, BF 24-TN (-ST)



**Tab. 2.2.2. Actuating mechanism BELIMO BF 24-TN(-ST), BF 230-TN**

<b>Actuating mechanism BELIMO</b>	<b>BF 24-TN(-ST)</b>	<b>BF 230-TN</b>
Nominal voltage	AC 24 V 50/60 Hz DC 24 V	AC 230 V 50/60 Hz
Power consumption - motoring - holding	7 W 2 W	8 W 3 W
Dimensioning	10 VA (Imax 8,3 A @ 5 ms)	12,5 VA (Imax 500 mA @ 5 ms)
Protection class	III	II
Degree of protection	IP 54	
Running time - motor - spring return	120 sec ~ 16 sec	
Ambient Temperature - normal duty - safety duty - non-operating temperature	-30°C ... +50°C The safe position will be attained up to max. 75°C -40°C ... +50°C	
Connecting - motor - auxiliary switch	cable 1 m, 2 x 0,75 mm <sup>2</sup> cable 1 m, 6 x 0,75 mm <sup>2</sup> (BF 24-T-ST) with plug-in connectors	
Thermal trips	Tf1: duct outside temperature Duct +72°C Tf2/Tf3: duct inside temperature Duct +72°C	

**Design .41, .51**

Design .41 or .51 with actuating mechanism can be complemented with smoke detector ORS 142 K. The voltage can be AC 230 V or 24 V DC. Design with voltage AC 230 V is equipped with Communication and supply device BKN 230-24-MOD and with actuating mechanism BF 24-TN (BFL 24-T, BFN 24-T).

The smoke detector is activated when smoke spreads in air duct system. Deactivation of smoke detector is provided by interruption of supply voltage for min. 2s.

Signalisation of damper blade position "OPEN" a "CLOSE" is provided by two limit switches..

**Tab. 2.2.3. Optical smoke detector ORS 142 K with the socket 143A**

<b>Optical smoke detector</b>	<b>ORS 142 K with socket 143A</b>
Operating voltage	18 ... 28 V DC
Residual ripple	≤ 200 mV
Power Consumption Socket (without actuating mechanism)	max. 22 mA
Degree of protection	IP 42
Ambient temperature	-20°C ... +75°C
Additional temperature sensor	+70°C
Connection - net - motor - communication and supply device BKN	Cabel 1m, connected to terminals 1, 2 and 4 Actuator connected on the terminals 2 and 5 Cabel 1m, connected to terminals 1, 2, 4 and 5

Fig. 16 Smoke detector ORS 142 K and socket 143A

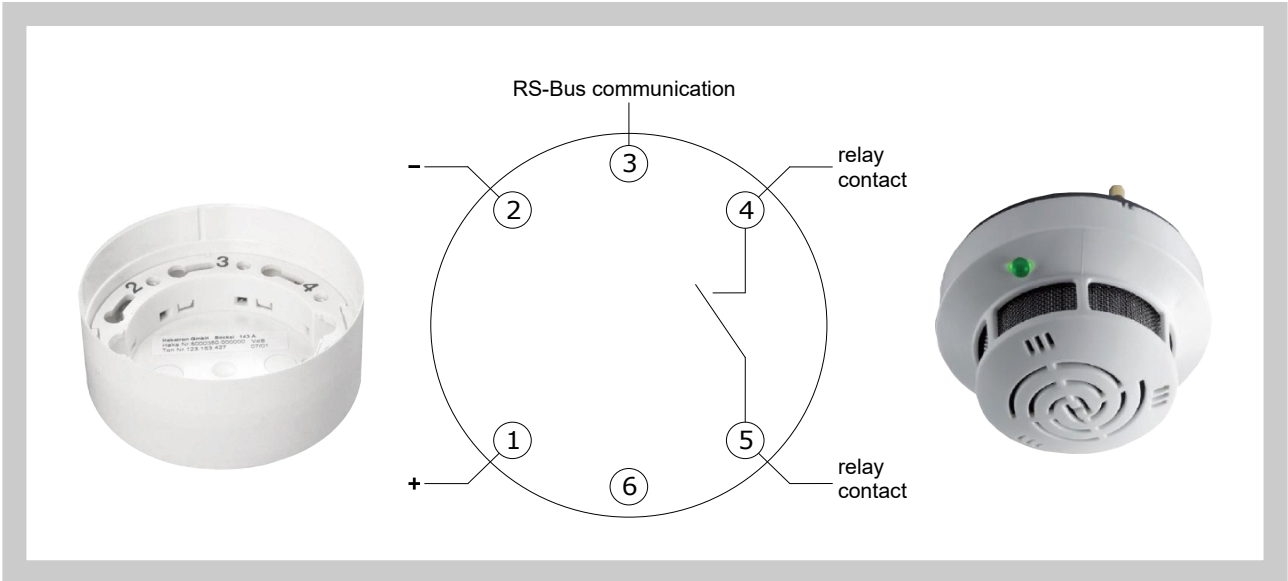


Fig. 17 Design with actuating mechanism BF 24-TN (BFL, BFN 24-T) , with smoke detector ORS 142 K and with communication and supply device BKN 230-24-MOD (voltage AC 230 V)

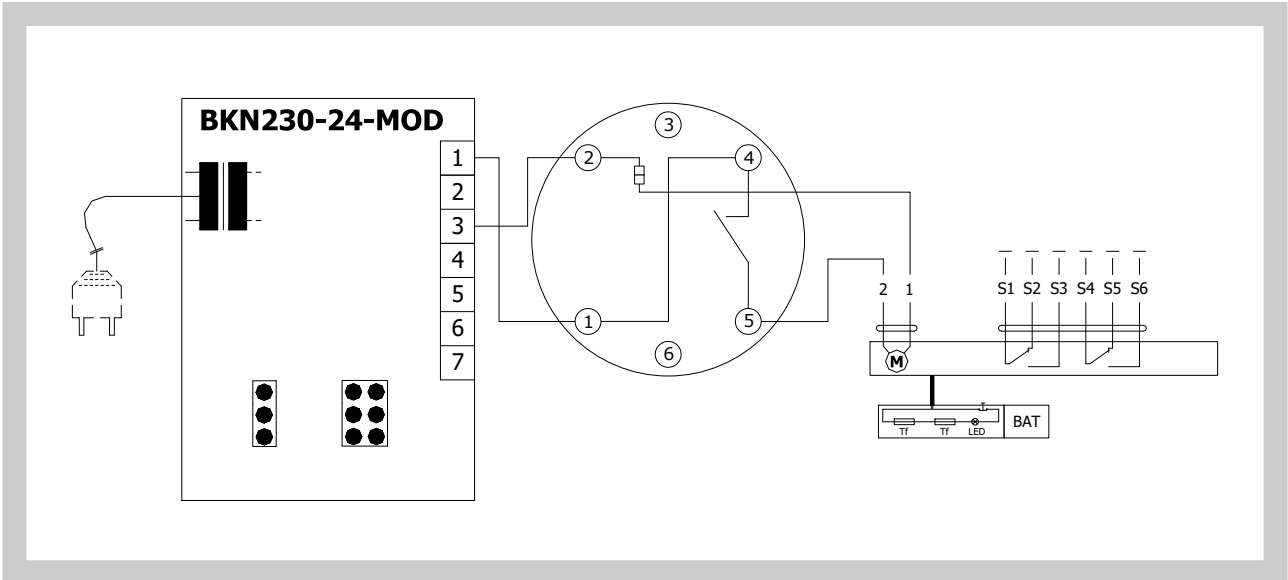
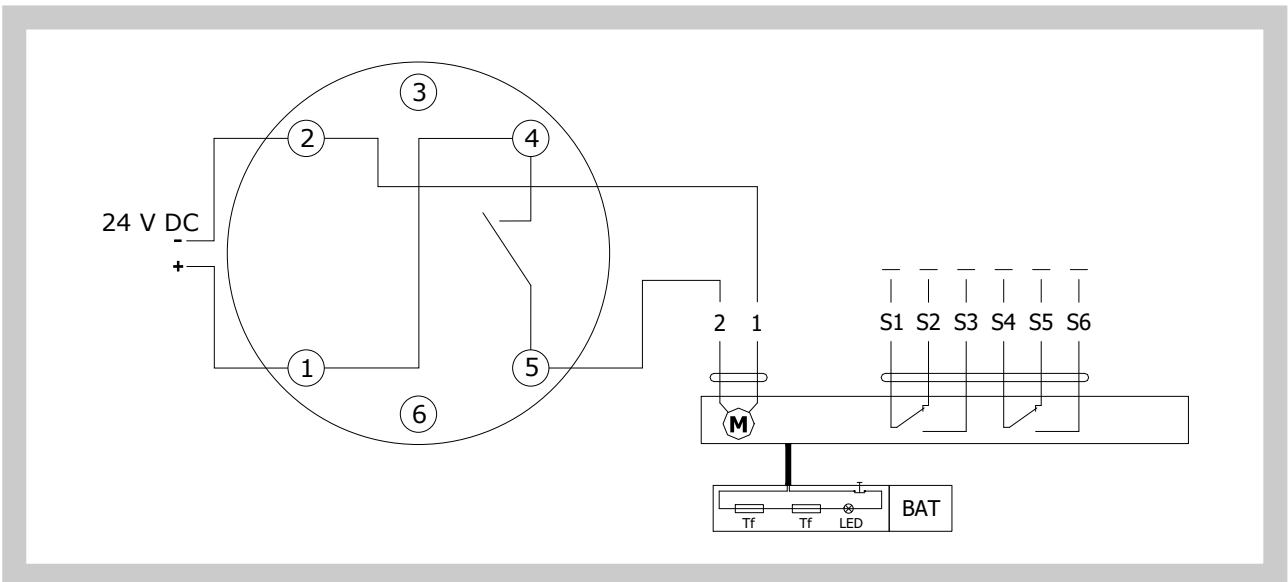


Fig. 18 Design with actuating mechanism BF 24-TN (BFL, BFN 24-T) , with smoke detector ORS 142 K (voltage 24 V DC)



**Design .63**

Design with communication and supply device can be complemented with smoke detector ORS 142 K. For supply and communication is used BKN 230-24-MOD, which is used together with the BF 24TN-ST (BFL 24T-ST, BFN 24T-ST) for communication with control systems using the Modbus RTU or BACnet MS / TP protocol. The wiring of the line is to be carried out in accordance with applicable RS485 regulations. Parameterization of the communication is done using DIL switches. The BKN 230-24-MOD can be installed separately, without a connection to a master control system, in which case the connection bridge between the terminals 1 and 4 must be installed. For more information, see the Belimo catalog.

**Tab. 2.3.3. Communication and supply device BKN 230-24-MOD**

<b>Communication and supply device</b>	<b>BKN 230-24-MOD</b>
Nominal voltage	AC 230 V 50/60Hz
Power consumption	3 W (operating position)
Dimensioning	14 VA (including actuating mechanism with spring return)
Protection Class	II
Degree of protection	IP 40
Ambient temperature Non-operating temperature	-20°C ... +50°C -40°C ... +80°C
Connection - net - motor - terminal board	cable 0,9 m with EURO plug type 26 6-pole connector, 3-pole connector screw terminals for cable 2x1,5 mm <sup>2</sup>

Fig. 19 Communication and supply device BKN 230-24-MOD, with act. mechanism BF 24-TN-ST (BFL 24-T-ST, BFN 24-T-ST)

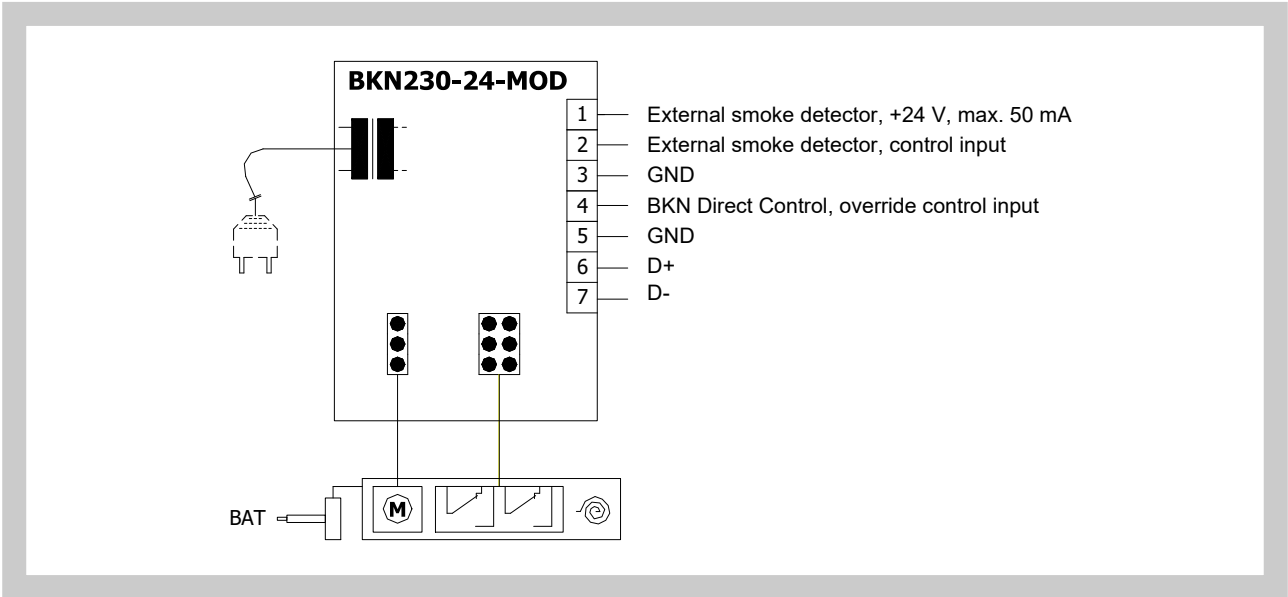
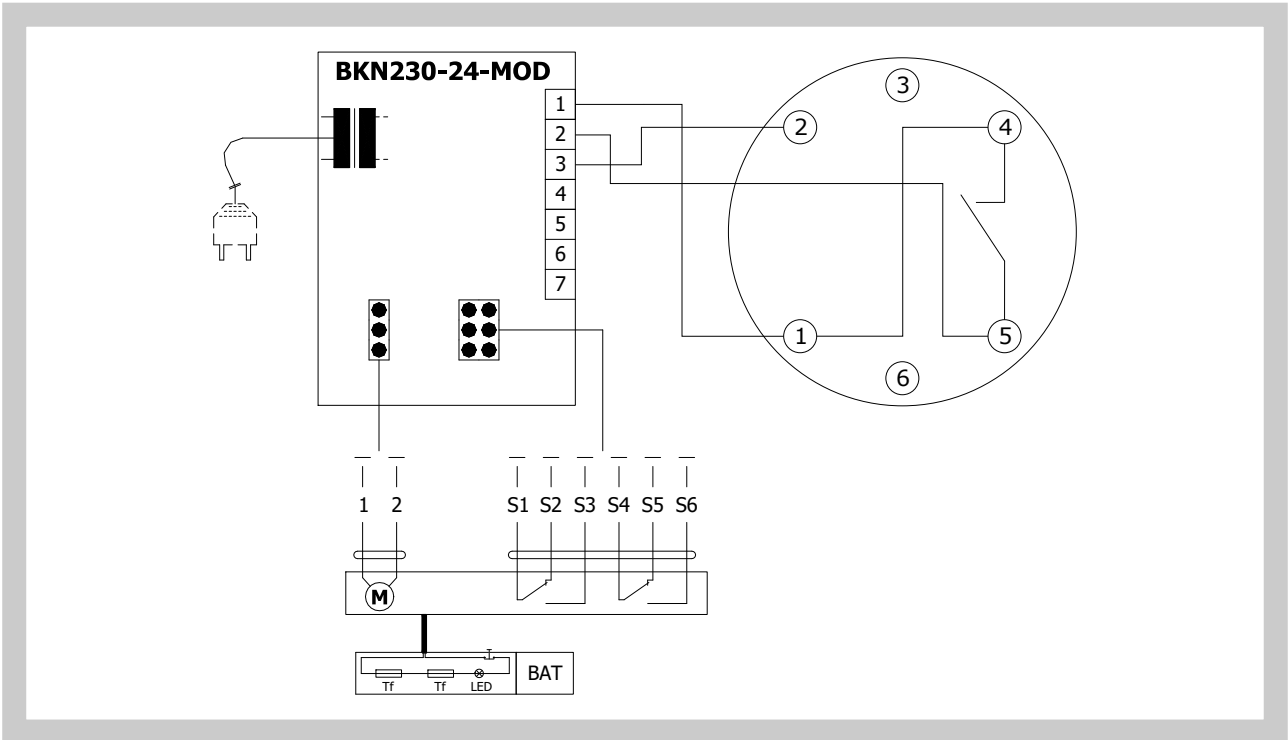


Fig. 20 Design with communication and supply device BKN 230-24-MOD, with actuating mechanism BF 24-TN-ST (BFL 24-T-ST, BFN 24-T-ST) and smoke detector ORS 142 K



3. Dimensions, weights and effective area

3.1. Dimensions

Fig. 21 Design manual and thermal

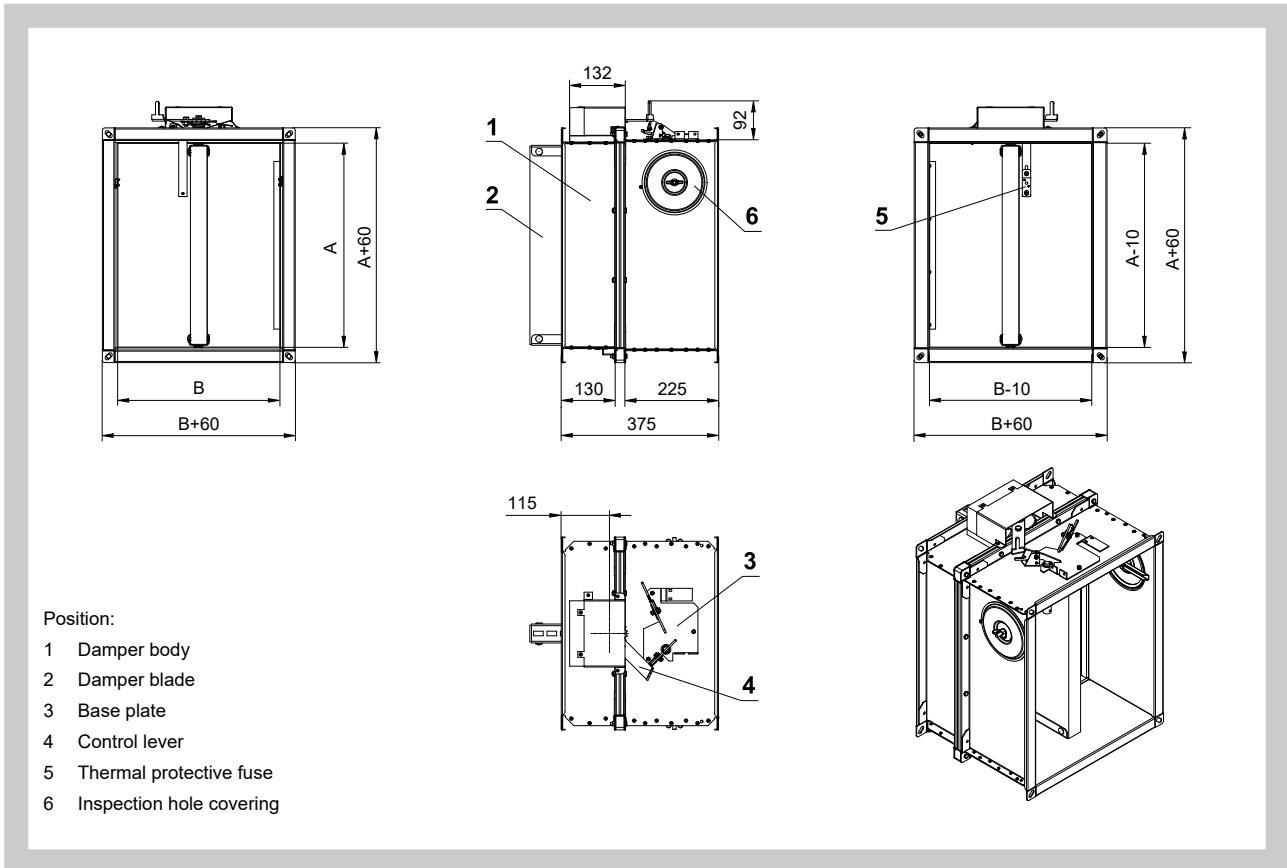
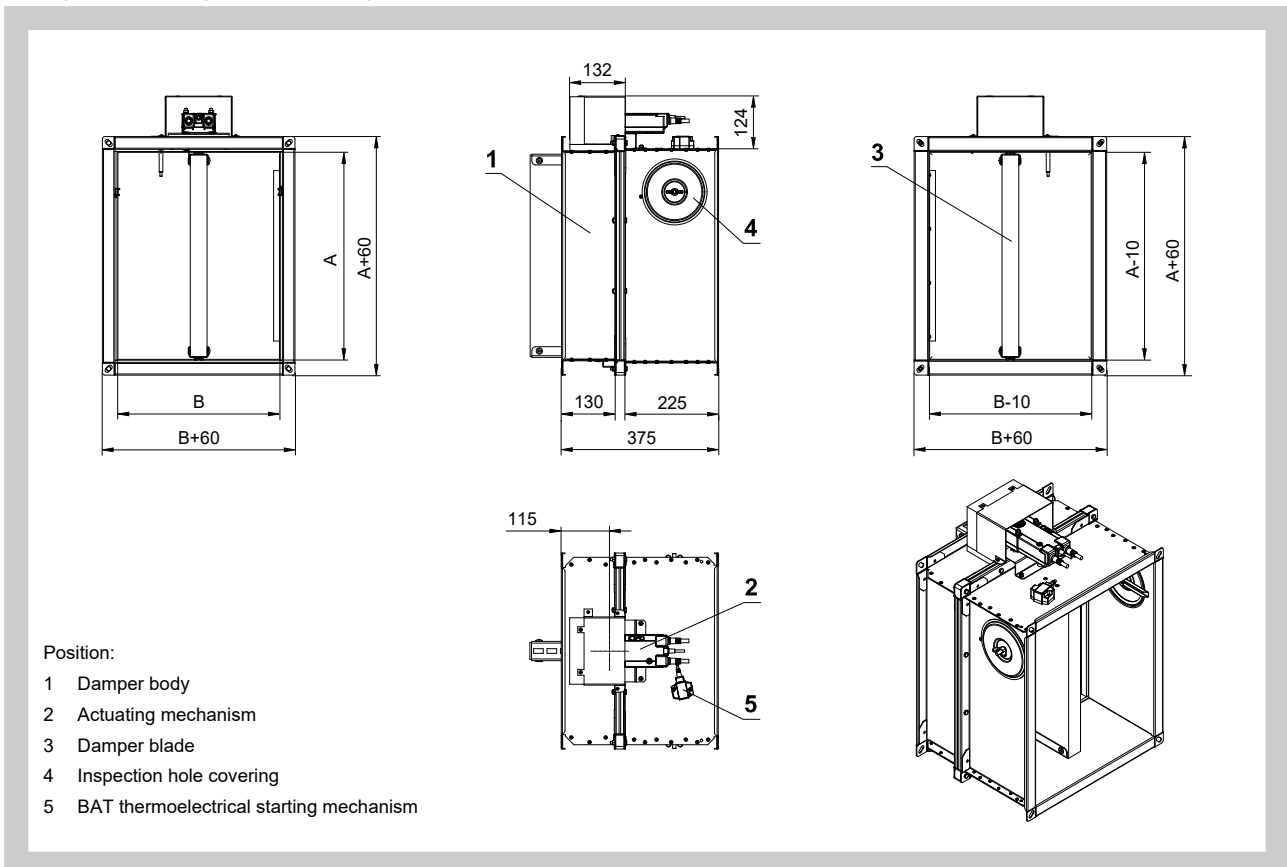


Fig. 22 Design with actuating mechanism



3.2. Dimensions, weights and effective area

Tab. 3.2.1. Dimensions, weights and effective area

A x B [mm]	a [mm]	c [mm]	Weight		Effect. area Sef [m <sup>2</sup> ]	Actu. mech.	A x B [mm]	a [mm]	c [mm]	Weight		Effect. area Sef [m <sup>2</sup> ]	Actu. mech.
			Design							Design			
			mech [kg]	servo [kg]						mech [kg]	servo [kg]		
180 x 180	-	-	9,0	10,7	0,0192	BFL	225 x 550	10	155	18,2	21,2	0,1005	BFL
x 200	-	-	9,4	11,1	0,0224	BFL	x 560	15	160	18,4	21,4	0,1025	BFL
x 225	-	-	9,9	11,6	0,0264	BFL	x 600	35	180	19,3	22,3	0,1107	BFL
x 250	-	5	10,5	12,2	0,0304	BFL	x 630	50	195	20,0	23,0	0,1169	BFN
x 280	-	20	11,1	12,8	0,0352	BFL	x 650	60	205	20,4	23,4	0,1210	BFN
x 300	-	30	11,5	13,2	0,0384	BFL	x 700	85	230	21,5	24,5	0,1312	BFN
x 315	-	37	11,8	13,5	0,0408	BFL	x 710	90	235	21,8	24,8	0,1333	BFN
x 355	-	57	12,7	14,4	0,0472	BFL	x 750	110	255	22,7	25,7	0,1415	BFN
x 400	-	80	13,6	15,3	0,0544	BFL	x 800	135	280	23,8	26,8	0,1517	BFN
x 450	-	105	14,6	17,6	0,0624	BFL	x 900	185	330	26,0	29,0	0,1722	BFN
x 500	-	130	15,7	18,7	0,0704	BFL	x 1000	235	380	28,3	31,3	0,1927	BF
x 550	10	155	16,7	19,7	0,0784	BFL	250 x 180	-	-	10,3	12,0	0,0276	BFL
x 560	15	160	16,9	19,9	0,0800	BFL	x 200	-	-	10,7	12,4	0,0322	BFL
x 600	35	180	17,8	20,8	0,0864	BFL	x 225	-	-	11,3	13,0	0,0380	BFL
x 630	50	195	18,4	21,4	0,0912	BFL	x 250	-	5	11,9	13,6	0,0437	BFL
x 650	60	205	18,8	21,8	0,0944	BFL	x 280	-	20	12,6	14,3	0,0506	BFL
x 700	85	230	19,9	22,9	0,1024	BFN	x 300	-	30	13,1	14,8	0,0552	BFL
x 710	90	235	20,1	23,1	0,1040	BFN	x 315	-	37	13,4	15,1	0,0587	BFL
x 750	110	255	20,9	23,9	0,1104	BFN	x 355	-	57	14,4	16,1	0,0679	BFL
x 800	135	280	22,0	25,0	0,1184	BFN	x 400	-	80	15,4	17,1	0,0782	BFL
200 x 180	-	-	9,4	11,1	0,0216	BFL	x 450	-	105	16,6	19,6	0,0897	BFL
x 200	-	-	9,8	11,5	0,0252	BFL	x 500	-	130	17,8	20,8	0,1012	BFL
x 225	-	-	10,3	12,0	0,0297	BFL	x 550	10	155	18,9	21,9	0,1127	BFL
x 250	-	5	10,9	12,6	0,0396	BFL	x 560	15	160	19,2	22,2	0,1150	BFL
x 280	-	20	11,5	13,2	0,0342	BFL	x 600	35	180	20,1	23,1	0,1242	BFN
x 300	-	30	12,0	13,7	0,0432	BFL	x 630	50	195	20,8	23,8	0,1311	BFN
x 315	-	37	12,3	14,0	0,0459	BFL	x 650	60	205	21,3	24,3	0,1357	BFN
x 355	-	57	13,1	14,8	0,0531	BFL	x 700	85	230	22,5	25,5	0,1472	BFN
x 400	-	80	14,1	15,8	0,0612	BFL	x 710	90	235	22,7	25,7	0,1495	BFN
x 450	-	105	15,2	18,2	0,0702	BFL	x 750	110	255	23,6	26,6	0,1587	BFN
x 500	-	130	16,3	19,3	0,0792	BFL	x 800	135	280	24,8	27,8	0,1702	BFN
x 550	10	155	17,4	20,4	0,0882	BFL	x 900	185	330	27,2	30,2	0,1932	BFN
x 560	15	160	17,6	20,6	0,0900	BFL	x 1000	235	380	29,5	32,5	0,2162	BF
x 600	35	180	18,4	21,4	0,0972	BFL	280 x 180	-	-	10,8	12,5	0,0312	BFL
x 630	50	195	19,1	22,1	0,1026	BFL	x 200	-	-	11,3	13,0	0,0364	BFL
x 650	60	205	19,5	22,5	0,1062	BFL	x 225	-	-	11,9	13,6	0,0429	BFL
x 700	85	230	20,6	23,6	0,1152	BFN	x 250	-	5	12,5	14,2	0,0494	BFL
x 710	90	235	20,8	23,8	0,1170	BFN	x 280	-	20	13,3	15,0	0,0572	BFL
x 750	110	255	21,7	24,7	0,1242	BFN	x 300	-	30	13,8	15,5	0,0624	BFL
x 800	135	280	22,8	25,8	0,1332	BFN	x 315	-	37	14,1	15,8	0,0663	BFL
x 900	185	330	24,9	27,9	0,1512	BFN	x 355	-	57	15,1	16,8	0,0767	BFL
x 1000	235	380	27,1	30,1	0,1692	BFN	x 400	-	80	16,2	17,9	0,0884	BFL
225 x 180	-	-	9,8	11,5	0,0246	BFL	x 450	-	105	17,4	20,4	0,1014	BFL
x 200	-	-	10,3	12,0	0,0287	BFL	x 500	-	130	18,7	21,7	0,1144	BFL
x 225	-	-	10,8	12,5	0,0338	BFL	x 550	10	155	19,9	22,9	0,1274	BFL
x 250	-	5	11,4	13,1	0,0390	BFL	x 560	15	160	20,1	23,1	0,1300	BFN
x 280	-	20	12,1	13,8	0,0451	BFL	x 600	35	180	21,1	24,1	0,1404	BFN
x 300	-	30	12,5	14,2	0,0492	BFL	x 630	50	195	21,9	24,9	0,1482	BFN
x 315	-	37	12,9	14,6	0,0523	BFL	x 650	60	205	22,4	25,4	0,1534	BFN
x 355	-	57	13,8	15,5	0,0605	BFL	x 700	85	230	23,6	26,6	0,1664	BFN
x 400	-	80	14,8	16,5	0,0697	BFL	x 710	90	235	23,8	26,8	0,1690	BFN
x 450	-	105	15,9	18,9	0,0800	BFL	x 750	110	255	24,8	27,8	0,1794	BFN
x 500	-	130	17,0	20,0	0,0902	BFL	x 800	135	280	26,0	29,0	0,1924	BFN

A x B [mm]	a [mm]	c [mm]	Weight		Effect. area Sef [m²]	Actu. mech.	A x B [mm]	a [mm]	c [mm]	Weight		Effect. area Sef [m²]	Actu. mech.
			Design							Design			
			mech [kg]	servo [kg]						mech [kg]	servo [kg]		
<b>280 x 900</b>	185	330	28,5	31,5	0,2184	BF	<b>355 x 450</b>	-	105	19,6	22,6	0,1307	BFL
<b>x 1000</b>	235	380	30,9	33,9	0,2444	BF	<b>x 500</b>	-	130	20,9	23,9	0,1474	BFN
<b>300 x 180</b>	-	-	11,2	12,9	0,0336	BFL	<b>x 550</b>	10	155	22,3	25,3	0,1642	BFN
<b>x 200</b>	-	-	11,7	13,4	0,0392	BFL	<b>x 560</b>	15	160	22,6	25,6	0,1675	BFN
<b>x 225</b>	-	-	12,3	14,0	0,0462	BFL	<b>x 600</b>	35	180	23,6	26,6	0,1809	BFN
<b>x 250</b>	-	5	13,0	14,7	0,0532	BFL	<b>x 630</b>	50	195	24,5	27,5	0,1910	BFN
<b>x 280</b>	-	20	13,7	15,4	0,0616	BFL	<b>x 650</b>	60	205	25,0	28,0	0,1977	BFN
<b>x 300</b>	-	30	14,2	15,9	0,0672	BFL	<b>x 700</b>	85	230	26,4	29,4	0,2144	BFN
<b>x 315</b>	-	37	14,6	16,3	0,0714	BFL	<b>x 710</b>	90	235	26,6	29,6	0,2178	BFN
<b>x 355</b>	-	57	15,6	17,3	0,0826	BFL	<b>x 750</b>	110	255	27,7	30,7	0,2312	BFN
<b>x 400</b>	-	80	16,8	18,5	0,0952	BFL	<b>x 800</b>	135	280	29,1	32,1	0,2479	BF
<b>x 450</b>	-	105	18,0	21,0	0,1092	BFL	<b>x 900</b>	185	330	31,8	34,8	0,2814	BF
<b>x 500</b>	-	130	19,3	22,3	0,1232	BFL	<b>x 1000</b>	235	380	34,5	37,5	0,3149	BF
<b>x 550</b>	10	155	20,5	23,5	0,1372	BFN	<b>400 x 180</b>	-	-	13,0	14,7	0,0456	BFL
<b>x 560</b>	15	160	20,8	23,8	0,1400	BFN	<b>x 200</b>	-	-	13,6	15,3	0,0532	BFL
<b>x 600</b>	35	180	21,8	24,8	0,1512	BFN	<b>x 225</b>	-	-	14,3	16,0	0,0627	BFL
<b>x 630</b>	50	195	22,6	25,6	0,1596	BFN	<b>x 250</b>	-	5	15,1	16,8	0,0722	BFL
<b>x 650</b>	60	205	23,1	26,1	0,1652	BFN	<b>x 280</b>	-	20	15,9	17,6	0,0836	BFL
<b>x 700</b>	85	230	24,3	27,3	0,1792	BFN	<b>x 300</b>	-	30	16,5	18,2	0,0912	BFL
<b>x 710</b>	90	235	24,6	27,6	0,1820	BFN	<b>x 315</b>	-	37	16,9	18,6	0,0969	BFL
<b>x 750</b>	110	255	25,6	28,6	0,1932	BFN	<b>x 355</b>	-	57	18,1	19,8	0,1121	BFL
<b>x 800</b>	135	280	26,8	29,8	0,2072	BFN	<b>x 400</b>	-	80	19,4	21,1	0,1292	BFL
<b>x 900</b>	185	330	29,4	32,4	0,2352	BF	<b>x 450</b>	-	105	20,8	23,8	0,1482	BFL
<b>x 1000</b>	235	380	31,9	34,9	0,2632	BF	<b>x 500</b>	-	130	22,3	25,3	0,1672	BFN
<b>315 x 180</b>	-	-	11,5	13,2	0,0354	BFL	<b>x 550</b>	10	155	23,7	26,7	0,1862	BFN
<b>x 200</b>	-	-	12,0	13,7	0,0413	BFL	<b>x 560</b>	15	160	24,0	27,0	0,1900	BFN
<b>x 225</b>	-	-	12,6	14,3	0,0487	BFL	<b>x 600</b>	35	180	25,1	28,1	0,2052	BFN
<b>x 250</b>	-	5	13,3	15,0	0,0561	BFL	<b>x 630</b>	50	195	26,0	29,0	0,2166	BFN
<b>x 280</b>	-	20	14,1	15,8	0,0649	BFL	<b>x 650</b>	60	205	26,6	29,6	0,2242	BFN
<b>x 300</b>	-	30	14,6	16,3	0,0708	BFL	<b>x 700</b>	85	230	28,0	31,0	0,2432	BFN
<b>x 315</b>	-	37	15,0	16,7	0,0752	BFL	<b>x 710</b>	90	235	28,3	31,3	0,2470	BFN
<b>x 355</b>	-	57	16,0	17,7	0,0870	BFL	<b>x 750</b>	110	255	29,5	32,5	0,2622	BF
<b>x 400</b>	-	80	17,1	18,8	0,1003	BFL	<b>x 800</b>	135	280	30,9	33,9	0,2812	BF
<b>x 450</b>	-	105	18,4	21,4	0,1151	BFL	<b>x 900</b>	185	330	33,8	36,8	0,3192	BF
<b>x 500</b>	-	130	19,7	22,7	0,1298	BFL	<b>x 1000</b>	235	380	36,7	39,7	0,3572	BF
<b>x 550</b>	10	155	21,0	24,0	0,1446	BFN	<b>450 x 180</b>	-	-	14,0	15,7	0,0516	BFL
<b>x 560</b>	15	160	21,3	24,3	0,1475	BFN	<b>x 200</b>	-	-	14,6	16,3	0,0602	BFL
<b>x 600</b>	35	180	22,3	25,3	0,1593	BFN	<b>x 225</b>	-	-	15,3	17,0	0,0710	BFL
<b>x 630</b>	50	195	23,1	26,1	0,1682	BFN	<b>x 250</b>	-	5	16,1	17,8	0,0817	BFL
<b>x 650</b>	60	205	23,6	26,6	0,1741	BFN	<b>x 280</b>	-	20	17,0	18,7	0,0946	BFL
<b>x 700</b>	85	230	24,9	27,9	0,1888	BFN	<b>x 300</b>	-	30	17,6	19,3	0,1032	BFL
<b>x 710</b>	90	235	25,1	28,1	0,1918	BFN	<b>x 315</b>	-	37	18,1	19,8	0,1097	BFL
<b>x 750</b>	110	255	26,2	29,2	0,2036	BFN	<b>x 355</b>	-	57	19,3	21,0	0,1269	BFL
<b>x 800</b>	135	280	27,5	30,5	0,2183	BFN	<b>x 400</b>	-	80	20,7	22,4	0,1462	BFL
<b>x 900</b>	185	330	30,0	33,0	0,2478	BF	<b>x 450</b>	-	105	22,2	25,2	0,1677	BFN
<b>x 1000</b>	235	380	32,6	35,6	0,2773	BF	<b>x 500</b>	-	130	23,8	26,8	0,1892	BFN
<b>355 x 180</b>	-	-	12,2	13,9	0,0402	BFL	<b>x 550</b>	10	155	25,3	28,3	0,2107	BFN
<b>x 200</b>	-	-	12,8	14,5	0,0469	BFL	<b>x 560</b>	15	160	25,6	28,6	0,2150	BFN
<b>x 225</b>	-	-	13,4	15,1	0,0553	BFL	<b>x 600</b>	35	180	26,8	29,8	0,2322	BFN
<b>x 250</b>	-	5	14,1	15,8	0,0737	BFL	<b>x 630</b>	50	195	27,7	30,7	0,2451	BFN
<b>x 280</b>	-	20	14,9	16,6	0,0637	BFL	<b>x 650</b>	60	205	28,4	31,4	0,2537	BFN
<b>x 300</b>	-	30	15,5	17,2	0,0804	BFL	<b>x 700</b>	85	230	29,9	32,9	0,2752	BF
<b>x 315</b>	-	37	15,9	17,6	0,0854	BFL	<b>x 710</b>	90	235	30,2	33,2	0,2795	BF
<b>x 355</b>	-	57	17,0	18,7	0,0988	BFL	<b>x 750</b>	110	255	31,4	34,4	0,2967	BF
<b>x 400</b>	-	80	18,2	19,9	0,1139	BFL	<b>x 800</b>	135	280	33,0	36,0	0,3182	BF



A x B [mm]	a [mm]	c [mm]	Weight		Effect. area Sef [m <sup>2</sup> ]	Actu. mech.	A x B [mm]	a [mm]	c [mm]	Weight		Effect. area Sef [m <sup>2</sup> ]	Actu. mech.
			Design							Design			
			mech [kg]	servo [kg]						mech [kg]	servo [kg]		
450 x 900	185	330	36,0	39,0	0,3612	BF	560 x 450	-	105	25,3	28,3	0,2106	BFN
x 1000	235	380	39,1	42,1	0,4042	BF	x 500	-	130	27,1	30,1	0,2376	BFN
500 x 180	-	-	14,9	16,6	0,0576	BFL	x 550	10	155	28,8	31,8	0,2646	BFN
x 200	-	-	15,5	17,2	0,0672	BFL	x 560	15	160	29,1	32,1	0,2700	BFN
x 225	-	-	16,3	18,0	0,0792	BFL	x 600	35	180	30,5	33,5	0,2916	BFN
x 250	-	5	17,1	18,8	0,0912	BFL	x 630	50	195	31,6	34,6	0,3078	BF
x 280	-	20	18,1	19,8	0,1056	BFL	x 650	60	205	32,2	35,2	0,3186	BF
x 300	-	30	18,8	20,5	0,1152	BFL	x 700	85	230	34,0	37,0	0,3456	BF
x 315	-	37	19,3	21,0	0,1224	BFL	x 710	90	235	34,3	37,3	0,3510	BF
x 355	-	57	20,6	22,3	0,1416	BFL	x 750	110	255	35,7	38,7	0,3726	BF
x 400	-	80	22,0	23,7	0,1632	BFL	x 800	135	280	37,4	40,4	0,3996	BF
x 450	-	105	23,6	26,6	0,1872	BFN	x 900	185	330	40,9	43,9	0,4536	BF
x 500	-	130	25,3	28,3	0,2112	BFN	x 1000	235	380	44,4	47,4	0,5076	BF
x 550	10	155	26,9	29,9	0,2352	BFN	600 x 180	-	-	16,7	19,7	0,0696	BFL
x 560	15	160	27,2	30,2	0,2400	BFN	x 200	-	-	17,4	20,4	0,0812	BFL
x 600	35	180	28,5	31,5	0,2592	BFN	x 225	-	-	18,3	21,3	0,0957	BFL
x 630	50	195	29,5	32,5	0,2736	BFN	x 250	-	5	19,2	22,2	0,1102	BFL
x 650	60	205	30,1	33,1	0,2832	BF	x 280	-	20	20,3	23,3	0,1276	BFL
x 700	85	230	31,7	34,7	0,3072	BF	x 300	-	30	21,0	24,0	0,1392	BFL
x 710	90	235	32,1	35,1	0,3120	BF	x 315	-	37	21,6	24,6	0,1479	BFL
x 750	110	255	33,4	36,4	0,3312	BF	x 355	-	57	23,0	26,0	0,1711	BFL
x 800	135	280	35,0	38,0	0,3552	BF	x 400	-	80	24,6	27,6	0,1972	BFN
x 900	185	330	38,2	41,2	0,4032	BF	x 450	-	105	26,4	29,4	0,2262	BFN
x 1000	235	380	41,5	44,5	0,4512	BF	x 500	-	130	28,3	31,3	0,2552	BFN
550 x 180	-	-	15,8	17,5	0,0636	BFL	x 550	10	155	30,1	33,1	0,2842	BFN
x 200	-	-	16,5	18,2	0,0742	BFL	x 560	15	160	30,4	33,4	0,2900	BFN
x 225	-	-	17,3	19,0	0,0875	BFL	x 600	35	180	31,9	34,9	0,3132	BF
x 250	-	5	18,2	19,9	0,1007	BFL	x 630	50	195	32,9	35,9	0,3306	BF
x 280	-	20	19,2	20,9	0,1166	BFL	x 650	60	205	33,7	36,7	0,3422	BF
x 300	-	30	19,9	21,6	0,1272	BFL	x 700	85	230	35,5	38,5	0,3712	BF
x 315	-	37	20,4	22,1	0,1352	BFL	x 710	90	235	35,8	38,8	0,3770	BF
x 355	-	57	21,8	23,5	0,1564	BFL	x 750	110	255	37,3	40,3	0,4002	BF
x 400	-	80	23,3	25,0	0,1802	BFN	x 800	135	280	39,1	42,1	0,4292	BF
x 450	-	105	25,0	28,0	0,2067	BFN	x 900	185	330	42,7	45,7	0,4872	BF
x 500	-	130	26,8	29,8	0,2332	BFN	x 1000	235	380	46,3	49,3	0,5452	BF
x 550	10	155	28,5	31,5	0,2597	BFN	630 x 180	-	-	17,3	20,3	0,0732	BFL
x 560	15	160	28,8	31,8	0,2650	BFN	x 200	-	-	18,0	21,0	0,0854	BFL
x 600	35	180	30,2	33,2	0,2862	BFN	x 225	-	-	18,9	21,9	0,1007	BFL
x 630	50	195	31,2	34,2	0,3021	BF	x 250	-	5	19,9	22,9	0,1159	BFL
x 650	60	205	31,9	34,9	0,3127	BF	x 280	-	20	21,0	24,0	0,1342	BFL
x 700	85	230	33,6	36,6	0,3392	BF	x 300	-	30	21,7	24,7	0,1464	BFL
x 710	90	235	33,9	36,9	0,3445	BF	x 315	-	37	22,3	25,3	0,1556	BFL
x 750	110	255	35,3	38,3	0,3657	BF	x 355	-	57	23,8	26,8	0,1800	BFL
x 800	135	280	37,0	40,0	0,3922	BF	x 400	-	80	25,4	28,4	0,2074	BFN
x 900	185	330	40,4	43,4	0,4452	BF	x 450	-	105	27,3	30,3	0,2379	BFN
x 1000	235	380	43,9	46,9	0,4982	BF	x 500	-	130	29,1	32,1	0,2684	BFN
560 x 180	-	-	16,0	17,7	0,0648	BFL	x 550	10	155	31,0	34,0	0,2989	BFN
x 200	-	-	16,7	18,4	0,0756	BFL	x 560	15	160	31,4	34,4	0,3050	BFN
x 225	-	-	17,5	19,2	0,0891	BFL	x 600	35	180	32,9	35,9	0,3294	BF
x 250	-	5	18,4	20,1	0,1026	BFL	x 630	50	195	34,0	37,0	0,3477	BF
x 280	-	20	19,4	21,1	0,1188	BFL	x 650	60	205	34,7	37,7	0,3599	BF
x 300	-	30	20,1	21,8	0,1296	BFL	x 700	85	230	36,6	39,6	0,3904	BF
x 315	-	37	20,7	22,4	0,1377	BFL	x 710	90	235	36,9	39,9	0,3965	BF
x 355	-	57	22,0	23,7	0,1593	BFL	x 750	110	255	38,4	41,4	0,4209	BF
x 400	-	80	23,6	25,3	0,1836	BFN	x 800	135	280	40,3	43,3	0,4514	BF

A x B [mm]	a [mm]	c [mm]	Weight		Effect. area Sef [m <sup>2</sup> ]	Actu. mech.	A x B [mm]	a [mm]	c [mm]	Weight		Effect. area Sef [m <sup>2</sup> ]	Actu. mech.
			Design							Design			
			mech [kg]	servo [kg]						mech [kg]	servo [kg]		
<b>630 x 900</b>	185	330	44,0	47,0	0,5124	BF	<b>710 x 450</b>	-	105	29,5	32,5	0,2691	BFN
<b>x 1000</b>	235	380	47,7	50,7	0,5734	BF	<b>x 500</b>	-	130	31,5	34,5	0,3036	BFN
<b>650 x 180</b>	-	-	17,6	20,6	0,0756	BFL	<b>x 550</b>	10	155	33,5	36,5	0,3381	BF
<b>x 200</b>	-	-	18,4	21,4	0,0882	BFL	<b>x 560</b>	15	160	33,9	36,9	0,3450	BF
<b>x 225</b>	-	-	19,3	22,3	0,1040	BFL	<b>x 600</b>	35	180	35,5	38,5	0,3726	BF
<b>x 250</b>	-	5	20,3	23,3	0,1197	BFL	<b>x 630</b>	50	195	36,7	39,7	0,3933	BF
<b>x 280</b>	-	20	21,4	24,4	0,1386	BFL	<b>x 650</b>	60	205	37,5	40,5	0,4071	BF
<b>x 300</b>	-	30	22,2	25,2	0,1512	BFL	<b>x 700</b>	85	230	39,5	42,5	0,4416	BF
<b>x 315</b>	-	37	22,7	25,7	0,1607	BFL	<b>x 710</b>	90	235	39,9	42,9	0,4485	BF
<b>x 355</b>	-	57	24,3	27,3	0,1859	BFL	<b>x 750</b>	110	255	41,5	44,5	0,4761	BF
<b>x 400</b>	-	80	26,0	29,0	0,2142	BFN	<b>x 800</b>	135	280	43,5	46,5	0,5106	BF
<b>x 450</b>	-	105	27,9	30,9	0,2457	BFN	<b>x 900</b>	185	330	47,5	50,5	0,5796	BF
<b>x 500</b>	-	130	29,7	32,7	0,2772	BFN	<b>x 1000</b>	235	380	51,5	54,5	0,6486	BF
<b>x 550</b>	10	155	31,6	34,6	0,3087	BFN	<b>750 x 180</b>	-	-	19,5	22,5	0,0876	BFL
<b>x 560</b>	15	160	32,0	35,0	0,3150	BF	<b>x 200</b>	-	-	20,3	23,3	0,1022	BFL
<b>x 600</b>	35	180	33,5	36,5	0,3402	BF	<b>x 225</b>	-	-	21,3	24,3	0,1205	BFL
<b>x 630</b>	50	195	34,7	37,7	0,3591	BF	<b>x 250</b>	-	5	22,4	25,4	0,1387	BFL
<b>x 650</b>	60	205	35,4	38,4	0,3717	BF	<b>x 280</b>	-	20	23,6	26,6	0,1606	BFL
<b>x 700</b>	85	230	37,3	40,3	0,4032	BF	<b>x 300</b>	-	30	24,5	27,5	0,1752	BFL
<b>x 710</b>	90	235	37,7	40,7	0,4095	BF	<b>x 315</b>	-	37	25,1	28,1	0,1862	BFL
<b>x 750</b>	110	255	39,2	42,2	0,4347	BF	<b>x 355</b>	-	57	26,7	29,7	0,2154	BFN
<b>x 800</b>	135	280	41,1	44,1	0,4662	BF	<b>x 400</b>	-	80	28,6	31,6	0,2482	BFN
<b>x 900</b>	185	330	44,9	47,9	0,5292	BF	<b>x 450</b>	-	105	30,7	33,7	0,2847	BFN
<b>x 1000</b>	235	380	48,7	51,7	0,5922	BF	<b>x 500</b>	-	130	32,7	35,7	0,3212	BFN
<b>700 x 180</b>	-	-	18,6	21,6	0,0816	BFL	<b>x 550</b>	10	155	34,8	37,8	0,3577	BF
<b>x 200</b>	-	-	19,4	22,4	0,0952	BFL	<b>x 560</b>	15	160	35,2	38,2	0,3650	BF
<b>x 225</b>	-	-	20,3	23,3	0,1122	BFL	<b>x 600</b>	35	180	36,9	39,9	0,3942	BF
<b>x 250</b>	-	5	21,3	24,3	0,1292	BFL	<b>x 630</b>	50	195	38,1	41,1	0,4161	BF
<b>x 280</b>	-	20	22,5	25,5	0,1496	BFL	<b>x 650</b>	60	205	39,0	42,0	0,4307	BF
<b>x 300</b>	-	30	23,3	26,3	0,1632	BFL	<b>x 700</b>	85	230	41,0	44,0	0,4672	BF
<b>x 315</b>	-	37	23,9	26,9	0,1734	BFL	<b>x 710</b>	90	235	41,4	44,4	0,4745	BF
<b>x 355</b>	-	57	25,5	28,5	0,2006	BFN	<b>x 750</b>	110	255	43,1	46,1	0,5037	BF
<b>x 400</b>	-	80	27,3	30,3	0,2312	BFN	<b>x 800</b>	135	280	45,2	48,2	0,5402	BF
<b>x 450</b>	-	105	29,3	32,3	0,2652	BFN	<b>x 900</b>	185	330	49,3	52,3	0,6132	BF
<b>x 500</b>	-	130	31,2	34,2	0,2992	BFN	<b>x 1000</b>	235	380	53,5	56,5	0,6862	BF
<b>x 550</b>	10	155	33,2	36,2	0,3332	BF	<b>800 x 180</b>	-	-	20,4	23,4	0,0936	BFL
<b>x 560</b>	15	160	33,6	36,6	0,3400	BF	<b>x 200</b>	-	-	21,3	24,3	0,1092	BFL
<b>x 600</b>	35	180	35,2	38,2	0,3672	BF	<b>x 225</b>	-	-	22,3	25,3	0,1287	BFL
<b>x 630</b>	50	195	36,4	39,4	0,3876	BF	<b>x 250</b>	-	5	23,4	26,4	0,1482	BFL
<b>x 650</b>	60	205	37,2	40,2	0,4012	BF	<b>x 280</b>	-	20	24,7	27,7	0,1716	BFL
<b>x 700</b>	85	230	39,2	42,2	0,4352	BF	<b>x 300</b>	-	30	25,6	28,6	0,1872	BFL
<b>x 710</b>	90	235	39,6	42,6	0,4420	BF	<b>x 315</b>	-	37	26,2	29,2	0,1989	BFL
<b>x 750</b>	110	255	41,2	44,2	0,4692	BF	<b>x 355</b>	-	57	28,0	31,0	0,2301	BFN
<b>x 800</b>	135	280	43,1	46,1	0,5032	BF	<b>x 400</b>	-	80	29,9	32,9	0,2652	BFN
<b>x 900</b>	185	330	47,1	50,1	0,5712	BF	<b>x 450</b>	-	105	32,1	35,1	0,3042	BFN
<b>x 1000</b>	235	380	51,1	54,1	0,6392	BF	<b>x 500</b>	-	130	34,2	37,2	0,3432	BFN
<b>710 x 180</b>	-	-	18,7	21,7	0,0828	BFL	<b>x 550</b>	10	155	36,4	39,4	0,3822	BF
<b>x 200</b>	-	-	19,5	22,5	0,0966	BFL	<b>x 560</b>	15	160	36,8	39,8	0,3900	BF
<b>x 225</b>	-	-	20,5	23,5	0,1139	BFL	<b>x 600</b>	35	180	38,6	41,6	0,4212	BF
<b>x 250</b>	-	5	21,5	24,5	0,1311	BFL	<b>x 630</b>	50	195	39,9	42,9	0,4446	BF
<b>x 280</b>	-	20	22,7	25,7	0,1518	BFL	<b>x 650</b>	60	205	40,7	43,7	0,4602	BF
<b>x 300</b>	-	30	23,5	26,5	0,1656	BFL	<b>x 700</b>	85	230	42,9	45,9	0,4992	BF
<b>x 315</b>	-	37	24,1	27,1	0,1760	BFL	<b>x 710</b>	90	235	43,3	46,3	0,5070	BF
<b>x 355</b>	-	57	25,7	28,7	0,2036	BFN	<b>x 750</b>	110	255	45,0	48,0	0,5382	BF
<b>x 400</b>	-	80	27,5	30,5	0,2346	BFN	<b>x 800</b>	135	280	47,2	50,2	0,5772	BF

A x B [mm]	a [mm]	c [mm]	Weight		Effect. area Sef [m²]	Actu. mech.	A x B [mm]	a [mm]	c [mm]	Weight		Effect. area Sef [m²]	Actu. mech.
			Design							Design			
			mech [kg]	servo [kg]						mech [kg]	servo [kg]		
800 x 900	185	330	51,5	54,5	0,6552	BF	1100 x 400	-	80	37,8	40,8	0,3672	BFN
x 1000	235	380	55,9	58,9	0,7332	BF	x 450	-	105	40,5	43,5	0,4212	BF
900 x 180	-	-	22,2	25,2	0,1056	BFL	x 500	-	130	43,2	46,2	0,4752	BF
x 200	-	-	23,2	26,2	0,1232	BFL	x 550	10	155	45,9	48,9	0,5292	BF
x 225	-	-	24,3	27,3	0,1452	BFL	x 560	15	160	46,5	49,5	0,5400	BF
x 250	-	5	25,5	28,5	0,1672	BFL	x 600	35	180	48,6	51,6	0,5832	BF
x 280	-	20	26,9	29,9	0,1936	BFL	x 630	50	195	50,2	53,2	0,6156	BF
x 300	-	30	27,9	30,9	0,2112	BFL	x 650	60	205	51,3	54,3	0,6372	BF
x 315	-	37	28,6	31,6	0,2244	BFN	x 700	85	230	54,0	57,0	0,6912	BF
x 355	-	57	30,4	33,4	0,2596	BFN	x 710	90	235	54,6	57,6	0,7020	BF
x 400	-	80	32,5	35,5	0,2992	BFN	x 750	110	255	56,7	59,7	0,7452	BF
x 450	-	105	34,9	37,9	0,3432	BFN	x 800	135	280	59,4	62,4	0,7992	BF
x 500	-	130	37,2	40,2	0,3872	BF	x 900	185	330	64,8	67,8	0,9072	BF
x 550	10	155	39,6	42,6	0,4312	BF	x 1000	235	380	70,2	73,2	1,0152	BF
x 560	15	160	40,0	43,0	0,4400	BF	1250 x 180	-	-	28,7	31,7	0,1476	BFL
x 600	35	180	41,9	44,9	0,4752	BF	x 200	-	-	29,9	32,9	0,1722	BFL
x 630	50	195	43,3	46,3	0,5016	BF	x 225	-	-	31,4	34,4	0,2030	BFL
x 650	60	205	44,3	47,3	0,5192	BF	x 250	-	5	32,8	35,8	0,2337	BFL
x 700	85	230	46,6	49,6	0,5632	BF	x 280	-	20	34,6	37,6	0,2706	BFN
x 710	90	235	47,1	50,1	0,5720	BF	x 300	-	30	35,8	38,8	0,2952	BFN
x 750	110	255	48,9	51,9	0,6072	BF	x 315	-	37	36,7	39,7	0,3137	BFN
x 800	135	280	51,3	54,3	0,6512	BF	x 355	-	57	39,1	42,1	0,3629	BFN
x 900	185	330	56,0	59,0	0,7392	BF	x 400	-	80	41,8	44,8	0,4182	BFN
x 1000	235	380	60,6	63,6	0,8272	BF	x 450	-	105	44,7	47,7	0,4797	BF
1000 x 180	-	-	24,1	27,1	0,1176	BFL	x 500	-	130	47,7	50,7	0,5412	BF
x 200	-	-	25,1	28,1	0,1372	BFL	x 550	10	155	50,7	53,7	0,6027	BF
x 225	-	-	26,4	29,4	0,1617	BFL	x 560	15	160	51,3	54,3	0,6150	BF
x 250	-	5	27,6	30,6	0,1862	BFL	x 600	35	180	53,6	56,6	0,6642	BF
x 280	-	20	29,1	32,1	0,2156	BFL	x 630	50	195	55,4	58,4	0,7011	BF
x 300	-	30	30,1	33,1	0,2352	BFN	x 650	60	205	56,6	59,6	0,7257	BF
x 315	-	37	30,9	33,9	0,2499	BFN	x 700	85	230	59,6	62,6	0,7872	BF
x 355	-	57	32,9	35,9	0,2891	BFN	x 710	90	235	60,2	63,2	0,7995	BF
x 400	-	80	35,2	38,2	0,3332	BFN	x 750	110	255	62,6	65,6	0,8487	BF
x 450	-	105	37,7	40,7	0,3822	BFN	x 800	135	280	65,5	68,5	0,9102	BF
x 500	-	130	40,2	43,2	0,4312	BF	x 900*	185	330	71,5	74,5	1,0332	BF
x 550	10	155	42,7	45,7	0,4802	BF	x 1000*	235	380	77,4	80,4	1,1562	BF
x 560	15	160	43,2	46,2	0,4900	BF	1400 x 180	-	-	31,4	34,4	0,1656	BFL
x 600	35	180	45,3	48,3	0,5292	BF	x 200	-	-	32,7	35,7	0,1932	BFL
x 630	50	195	46,8	49,8	0,5586	BF	x 225	-	-	34,4	37,4	0,2277	BFL
x 650	60	205	47,8	50,8	0,5782	BF	x 250	-	5	36,0	39,0	0,2622	BFN
x 700	85	230	50,3	53,3	0,6272	BF	x 280	-	20	37,9	40,9	0,3036	BFN
x 710	90	235	50,8	53,8	0,6370	BF	x 300	-	30	39,2	42,2	0,3312	BFN
x 750	110	255	52,8	55,8	0,6762	BF	x 315	-	37	40,2	43,2	0,3519	BFN
x 800	135	280	55,3	58,3	0,7252	BF	x 355	-	57	42,8	45,8	0,4071	BFN
x 900	185	330	60,4	63,4	0,8232	BF	x 400	-	80	45,7	48,7	0,4692	BF
x 1000	235	380	65,4	68,4	0,9212	BF	x 450	-	105	48,9	51,9	0,5382	BF
1100 x 180	-	-	25,9	28,9	0,1296	BFL	x 500	-	130	52,2	55,2	0,6072	BF
x 200	-	-	27,0	30,0	0,1512	BFL	x 550	10	155	55,4	58,4	0,6762	BF
x 225	-	-	28,4	31,4	0,1782	BFL	x 560	15	160	56,1	59,1	0,6900	BF
x 250	-	5	29,7	32,7	0,2052	BFL	x 600	35	180	58,7	61,7	0,7452	BF
x 280	-	20	31,3	34,3	0,2376	BFL	x 630*	50	195	60,6	63,6	0,7866	BF
x 300	-	30	32,4	35,4	0,2592	BFN	x 650*	60	205	61,9	64,9	0,8142	BF
x 315	-	37	33,2	36,2	0,2754	BFN	x 700*	85	230	65,2	68,2	0,8832	BF
x 355	-	57	35,4	38,4	0,3186	BFN	x 710*	90	235	65,8	68,8	0,8970	BF

\* for these dimensions are used two closing springs

A x B [mm]	a [mm]	c [mm]	Weight		Effect. area Sef [m²]	Actu. mech.	A x B [mm]	a [mm]	c [mm]	Weight		Effect. area Sef [m²]	Actu. mech.
			Design							Design			
			mech [kg]	servo [kg]						mech [kg]	servo [kg]		
<b>1400 x 750*</b>	110	255	68,4	71,4	0,9522	BF	<b>1500 x 900*</b>	185	330	82,6	85,6	1,2432	BF
<b>x 800*</b>	135	280	71,6	74,6	1,0212	BF	<b>x 1000*</b>	235	380	89,4	92,4	1,3912	BF
<b>x 900*</b>	185	330	78,1	81,1	1,1592	BF	<b>1600 x 180</b>	-	-	35,1	38,1	0,1896	BFL
<b>x 1000*</b>	235	380	84,6	87,6	1,2972	BF	<b>x 200</b>	-	-	36,6	39,6	0,2212	BFL
<b>1500 x 180</b>	-	-	33,3	36,3	0,1776	BFL	<b>x 225</b>	-	-	38,4	41,4	0,2607	BFL
<b>x 200</b>	-	-	34,7	37,7	0,2072	BFL	<b>x 250</b>	-	5	40,2	43,2	0,3002	BFN
<b>x 225</b>	-	-	36,4	39,4	0,2442	BFL	<b>x 280</b>	-	20	42,3	45,3	0,3476	BFN
<b>x 250</b>	-	5	38,1	41,1	0,2812	BFN	<b>x 300</b>	-	30	43,8	46,8	0,3792	BFN
<b>x 280</b>	-	20	40,1	43,1	0,3256	BFN	<b>x 315</b>	-	37	44,8	47,8	0,4029	BFN
<b>x 300</b>	-	30	41,5	44,5	0,3552	BFN	<b>x 355</b>	-	57	47,7	50,7	0,4661	BFN
<b>x 315</b>	-	37	42,5	45,5	0,3774	BFN	<b>x 400</b>	-	80	51,0	54,0	0,5372	BF
<b>x 355</b>	-	57	45,3	48,3	0,4366	BFN	<b>x 450</b>	-	105	54,6	57,6	0,6162	BF
<b>x 400</b>	-	80	48,3	51,3	0,5032	BF	<b>x 500</b>	-	130	58,2	61,2	0,6952	BF
<b>x 450</b>	-	105	51,8	54,8	0,5772	BF	<b>x 550</b>	10	155	61,8	64,8	0,7742	BF
<b>x 500</b>	-	130	55,2	58,2	0,6512	BF	<b>x 560</b>	15	160	62,5	65,5	0,7900	BF
<b>x 550</b>	10	155	58,6	61,6	0,7252	BF	<b>x 600</b>	35	180	65,4	68,4	0,8532	BF
<b>x 560</b>	15	160	59,3	62,3	0,7400	BF	<b>x 630*</b>	50	195	67,5	70,5	0,9006	BF
<b>x 600</b>	35	180	62,0	65,0	0,7992	BF	<b>x 650*</b>	60	205	69,0	72,0	0,9322	BF
<b>x 630*</b>	50	195	64,1	67,1	0,8436	BF	<b>x 700*</b>	85	230	72,6	75,6	1,0112	BF
<b>x 650*</b>	60	205	65,4	68,4	0,8732	BF	<b>x 710*</b>	90	235	73,3	76,3	1,0270	BF
<b>x 700*</b>	85	230	68,9	71,9	0,9472	BF	<b>x 750*</b>	110	255	76,2	79,2	1,0902	BF
<b>x 710*</b>	90	235	69,6	72,6	0,9620	BF	<b>x 800*</b>	135	280	79,8	82,8	1,1692	BF
<b>x 750*</b>	110	255	72,3	75,3	1,0212	BF	<b>x 900*</b>	185	330	87,0	90,0	1,3272	BF
<b>x 800*</b>	135	280	75,7	78,7	1,0952	BF	<b>x 1000*</b>	235	380	94,2	97,2	1,4852	BF

\* for these dimensions are used two closing springs

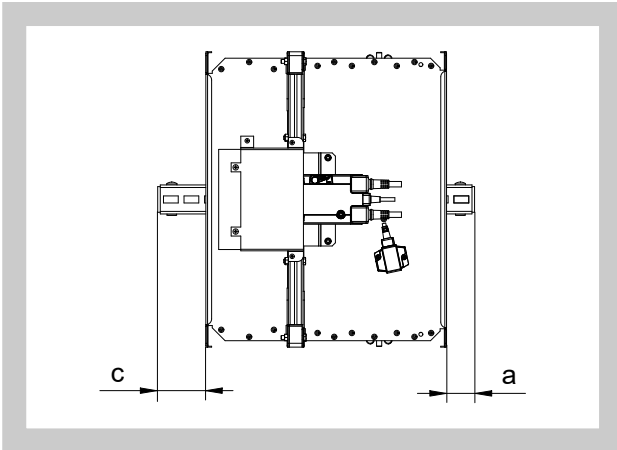
**3.3. Blades overlaps**

**Tab. 3.3.1 Blades overlaps**

Blades overlaps		Dimension	Overlaps
Blades overlaps Fig. 23	Act. mechanism side	"a"	Tab. 3.2.1
	Side without act. mechanism	"c"	Tab. 3.2.1

These values has to be respected when projecting related air-conditioning ducts.

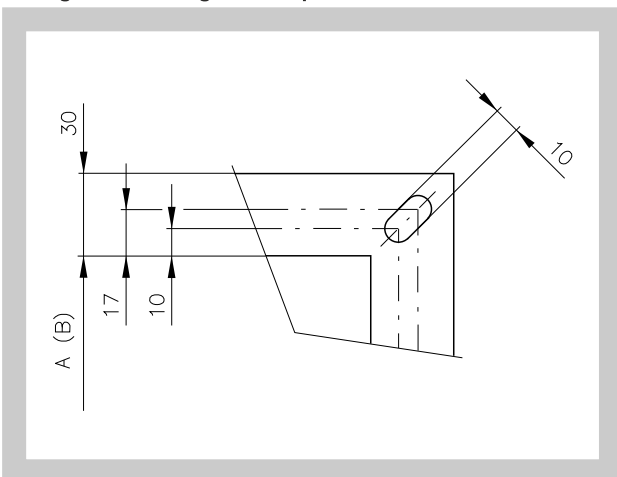
**Fig. 23 Blades overlaps**



**3.4.** Dampers can be supplied on the customer’s demands in all subdimension of the above mentioned range.

**3.5.** Flanges of dampers are 30 mm wide with oval hole (Fig. 24).

**Fig. 24 Flange of Damper**



**4. Placement and Assembly**

- 4.1.** Fire dampers are suitable for installation in arbitrary position in vertical and horizontal passages of fire separating constructions. Damper assembly procedures must be done so as all load transfer from the fire separating constructions to the damper body is absolutely excluded. Back-to-back air-conditioning piping must be hung or supported so as all load transfer from the back-to-back piping to the damper is absolutely excluded. Installation gap must be filled by approved material perfectly in all the installation space volume (installation gap).

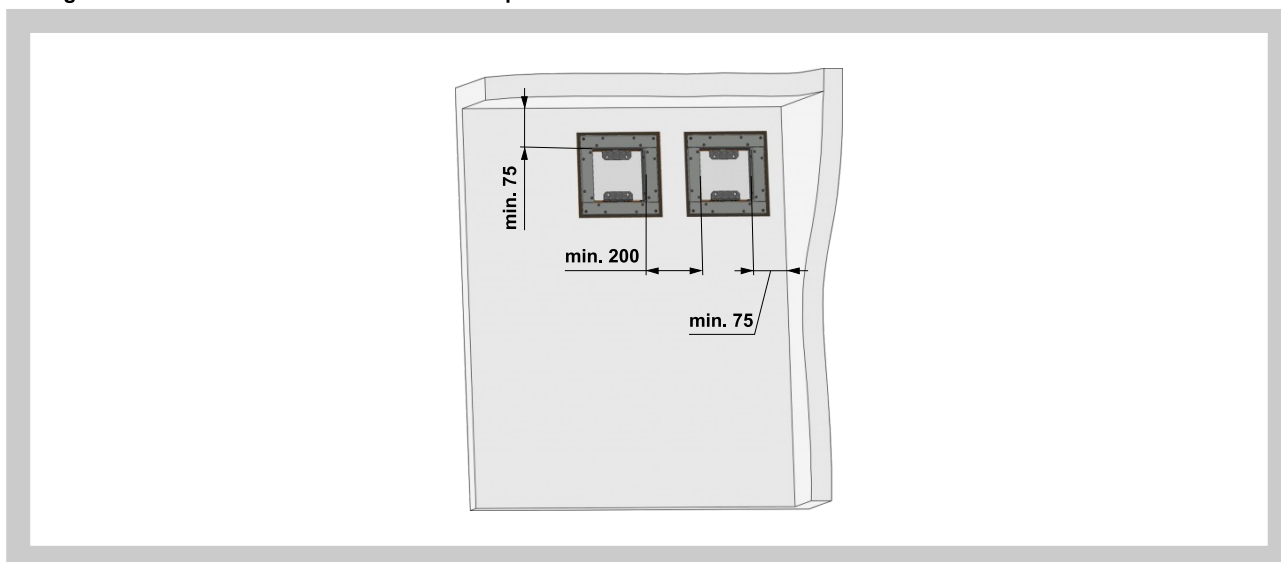
To provide needed access space to the control device, all other objects must be situated at least 350 mm from the control parts of the damper. Inspection hole must be accessible.

Damper blade has to be inside of construction (labelled with BUILD IN EDGE on the damper body) after installation. The fire damper can also be installed outside the wall construction. Duct and the damper part between the wall construction and the damper blade (labelled with BUILD IN EDGE on the protective covering) must be protected with firefighting insulation.

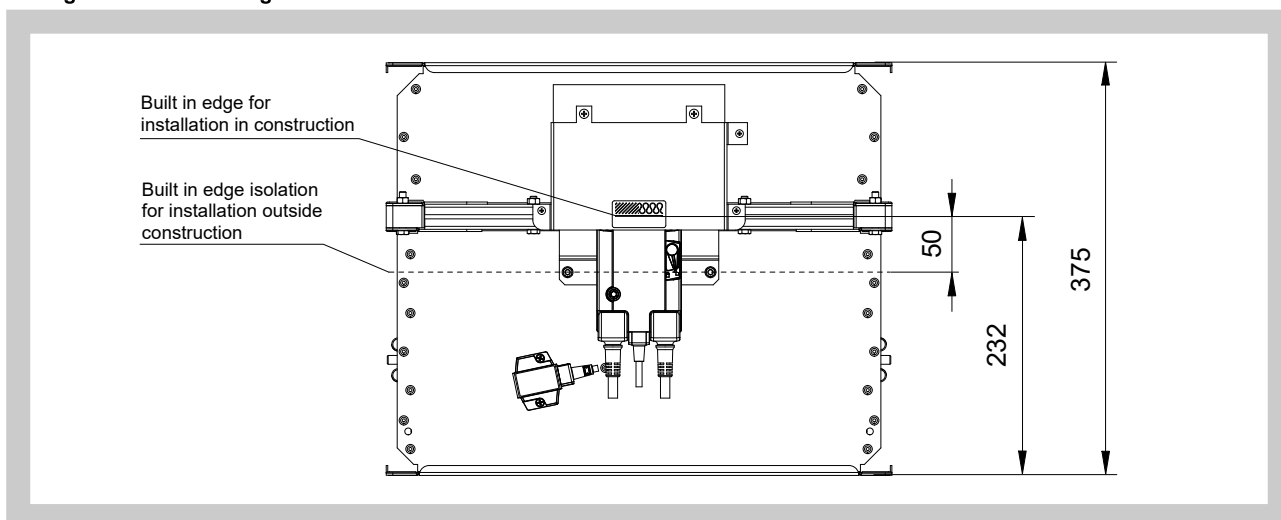
The distance between the fire damper and the construction (wall, ceiling) must be minimum 75 mm. In case that two or more dampers are supposed to be installed in one fire separating construction, the distance between the adjacent dampers must be at least 200 mm according to EN 1366-2 paragraph 13.5.

Exceptions are given in [chapter 5](#).

**Fig. 25 The distance between the fire damper and the construction**

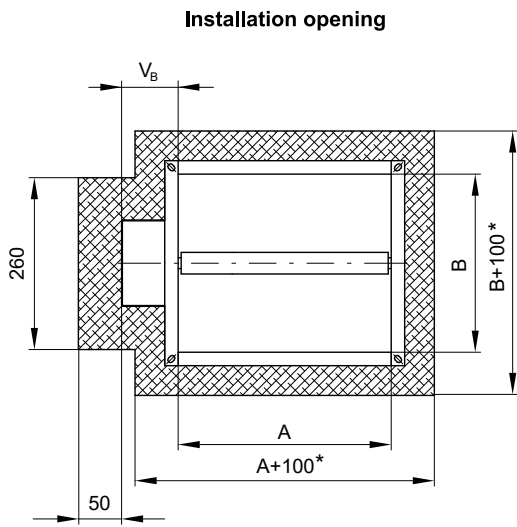


**Fig. 26 Built in edge**

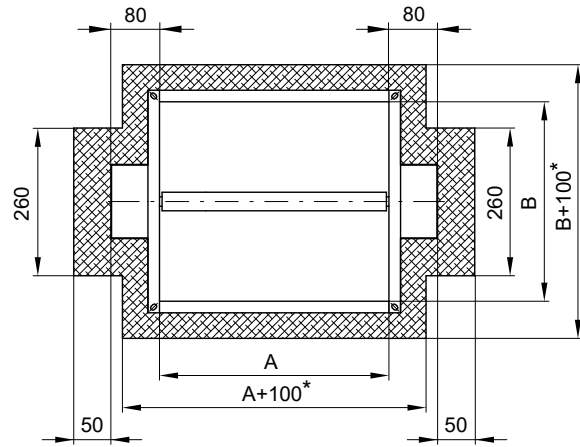


"Wall edge sticker" indicates the recommended edge of installation of fire damper into the fire partition structure (wall). The damper must be installed so that the entire damper blade - in the closed position - is located inside the fire separating structure (wall) and at the same time the control mechanism and inspection openings are freely accessible.

Fig. 27 Installation opening



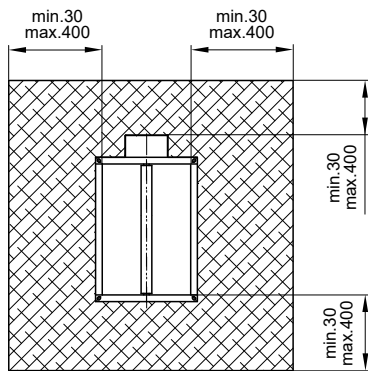
Installation opening - with two sprigs (two mechanics)



$V_B = 80$  ... mechanics  
 125 ... BELIMO actuators  
 145 ... SCHISCHEK actuators

\* The recommended dimension of the installation opening is from 25 mm to 50 mm on the both sides (it means from  $A+50$  to  $A+100$  or  $B+50$  to  $B+100$ )

Installation opening  
 Ablative Coated Batt



**5. Statement of installations**

**5.1. Installation method list**

**Tab. 5.1.1. Installation method list**

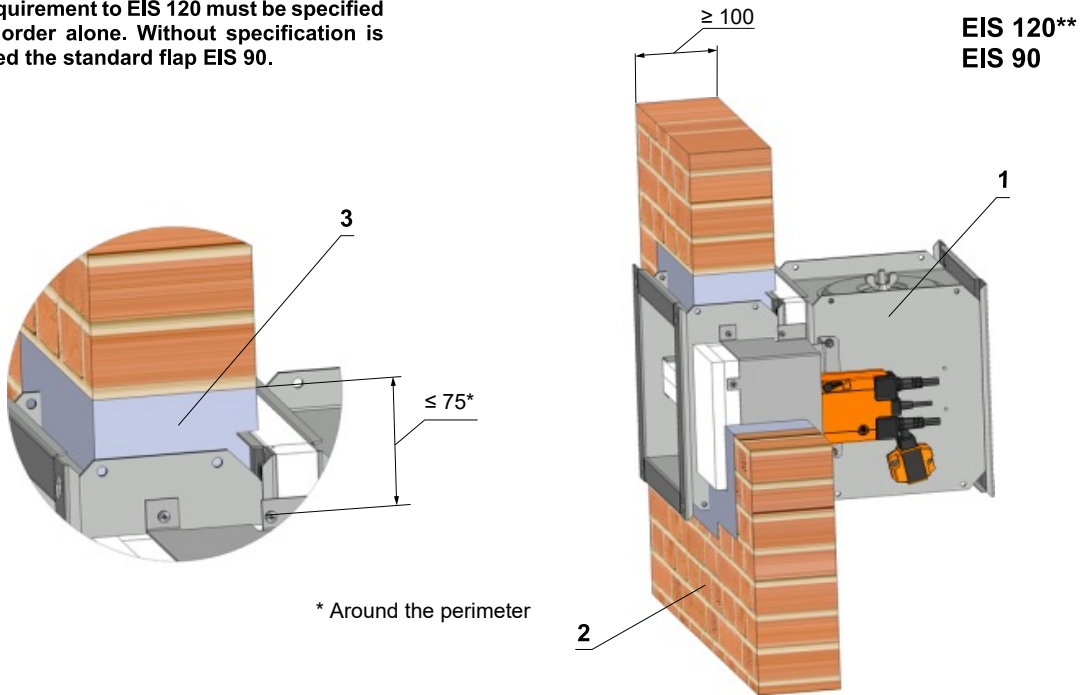
Fire separating constru.	Wall/Ceiling	Installation	Fire resist.	Page
	Min. thickness [mm]			
Solid wall construction	100	Mortar or gypsum	EIS 120 EIS 90	25
	100	Fire protection foam with stucco plaster	EIS 60 EIS 45 EIS 30	25
	100	Installation next to wall - mortar or gypsum and mineral wool	EIS 90	26
	100	Stuffing box with fire protection mastic and cement lime plate	EIS 90	27
	100	Ablative Coated Batt	EIS 90	28
Outside solid wall construction	100	Mineral wool - mortar or gypsum	EIS 60	29
	100	Mineral wool - stuffing box and fire protection mastic	EIS 60	29
	100	Mineral wool, stuffing box, fire protection mastic and cement lime plate	EIS 90	30
Gypsum wall construction	100	Mortar or gypsum	EIS 120 EIS 90	31
	100	Fire protection foam with stucco plaster	EIS 60 EIS 45 EIS 30	31
	100	Stuffing box with fire protection mastic and cement lime plate	EIS 90	32
	100	Ablative Coated Batt	EIS 90	33
Outside gypsum wall construction	100	Mineral wool - mortar or gypsum	EIS 60	34
	100	Mineral wool - stuffing box and fire protection mastic	EIS 60	34
	100	Mineral wool, stuffing box, fire protection mastic and cement lime plate	EIS 90	35
Solid ceiling construction	150	Mortar or gypsum	EIS 120 EIS 90	36
		Stuffing box with fire protection mastic and cement lime plate	EIS 90	37
		Ablative Coated Batt	EIS 90	38
Outside solid ceiling construction	150	Mineral wool - mortar or gypsum	EIS 90	39



5.2. Installation in solid wall construction

Fig. 28 Solid wall construction - mortar or gypsum

\*\* The requirement to EIS 120 must be specified in the order alone. Without specification is supplied the standard flap EIS 90.



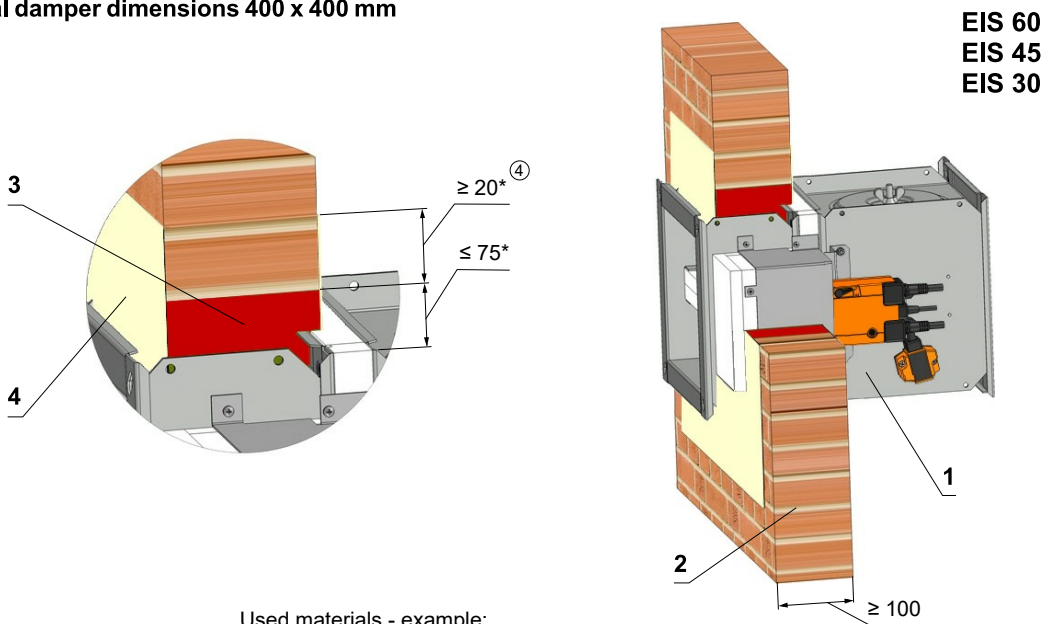
\* Around the perimeter

Position:

- 1 Fire damper
- 2 Solid wall construction
- 3 Mortar or gypsum

Fig. 29 Solid wall construction - fire protection foam with stucco plaster

Maximal damper dimensions 400 x 400 mm



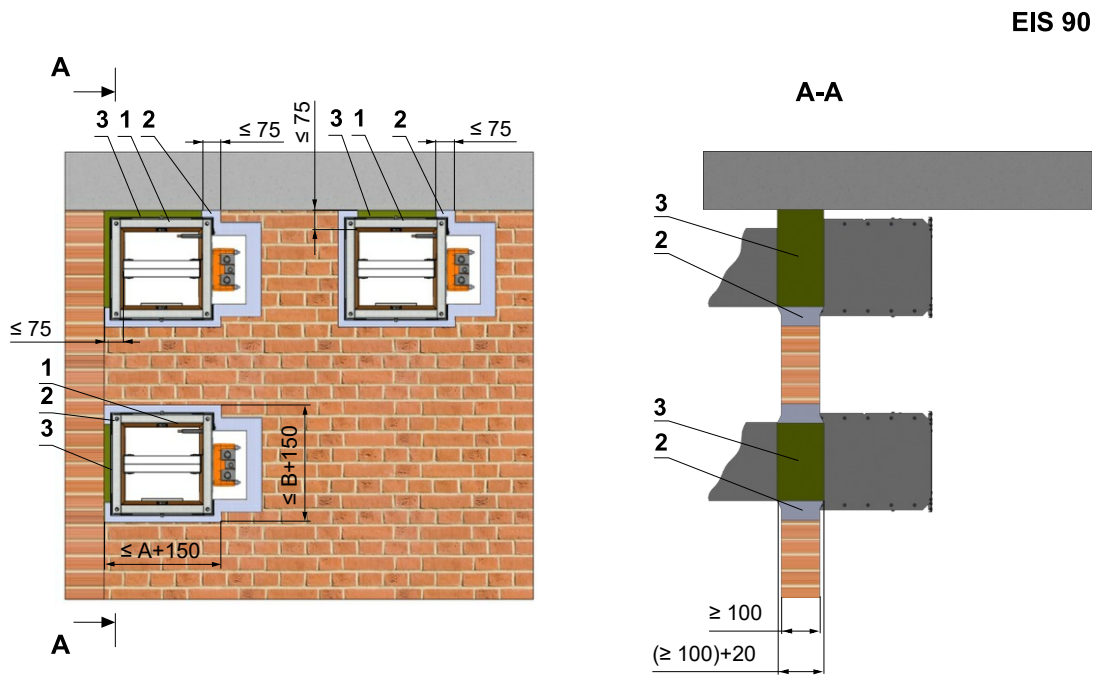
Used materials - example:

Position:

- 1 Fire damper
- 2 Solid wall construction
- 3 Fire protection foam
- 4 Stucco plaster

- 3 HILTI CFS-F FX - EIS 60
- PROMAFOAM-C - EIS 45
- SOULDAL, Soudafoam FR-B1 - EIS 30
- DenBraven, Fire protection foam - EIS 30

Fig. 30 Solid wall construction - installation next to wall, ceiling - mortar or gypsum and mineral wool



Position:

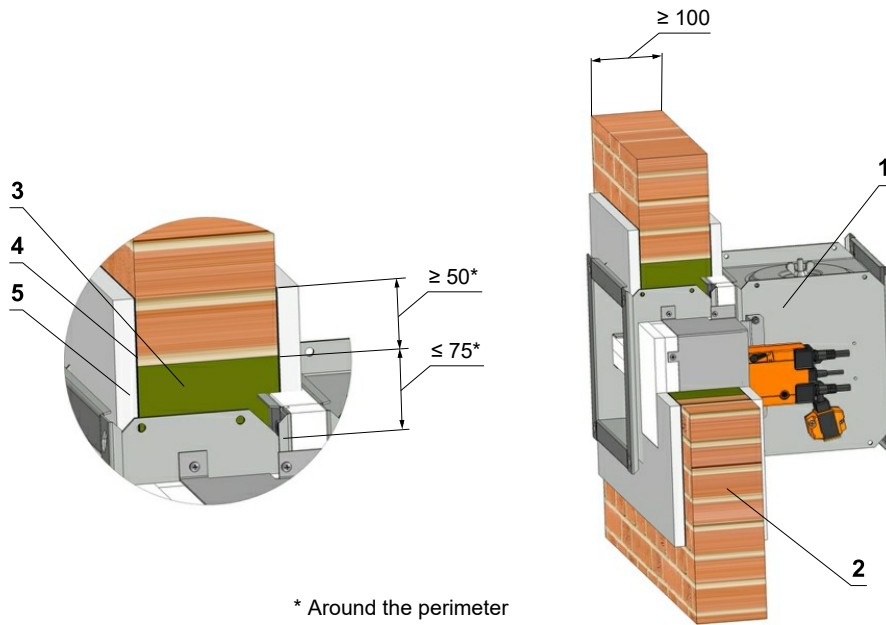
- 1 Fire damper
- 2 Mortar or gypsum
- 3 Mineral stone wool min. density 140 kg/m<sup>3</sup>

**Notice:**

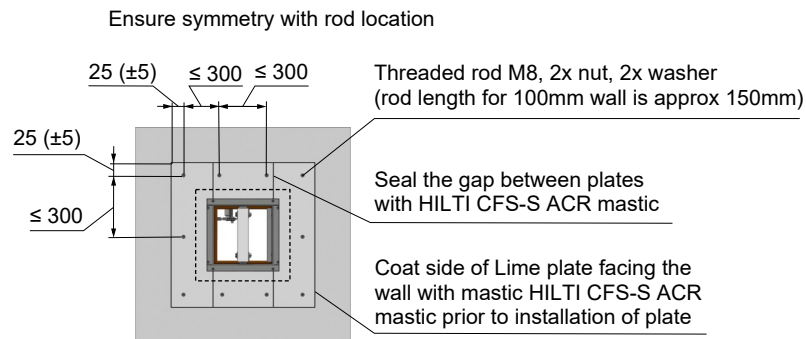
- Gap between damper and construction is filled by mortar or gypsum and mineral wool
- Wool is fixed to damper body and construction by fire protection mastic
- Mineral wool thickness = construction thickness + 20 mm or 50 mm
- Installation is valid for ceiling construction

Fig. 31 Solid wall construction - stuffing box, fire protection mastic and cement lime plate

EIS 90



\* Around the perimeter



Screws has to be fixed in wall/ceiling construction.  
(If it is needed use steel bracket).

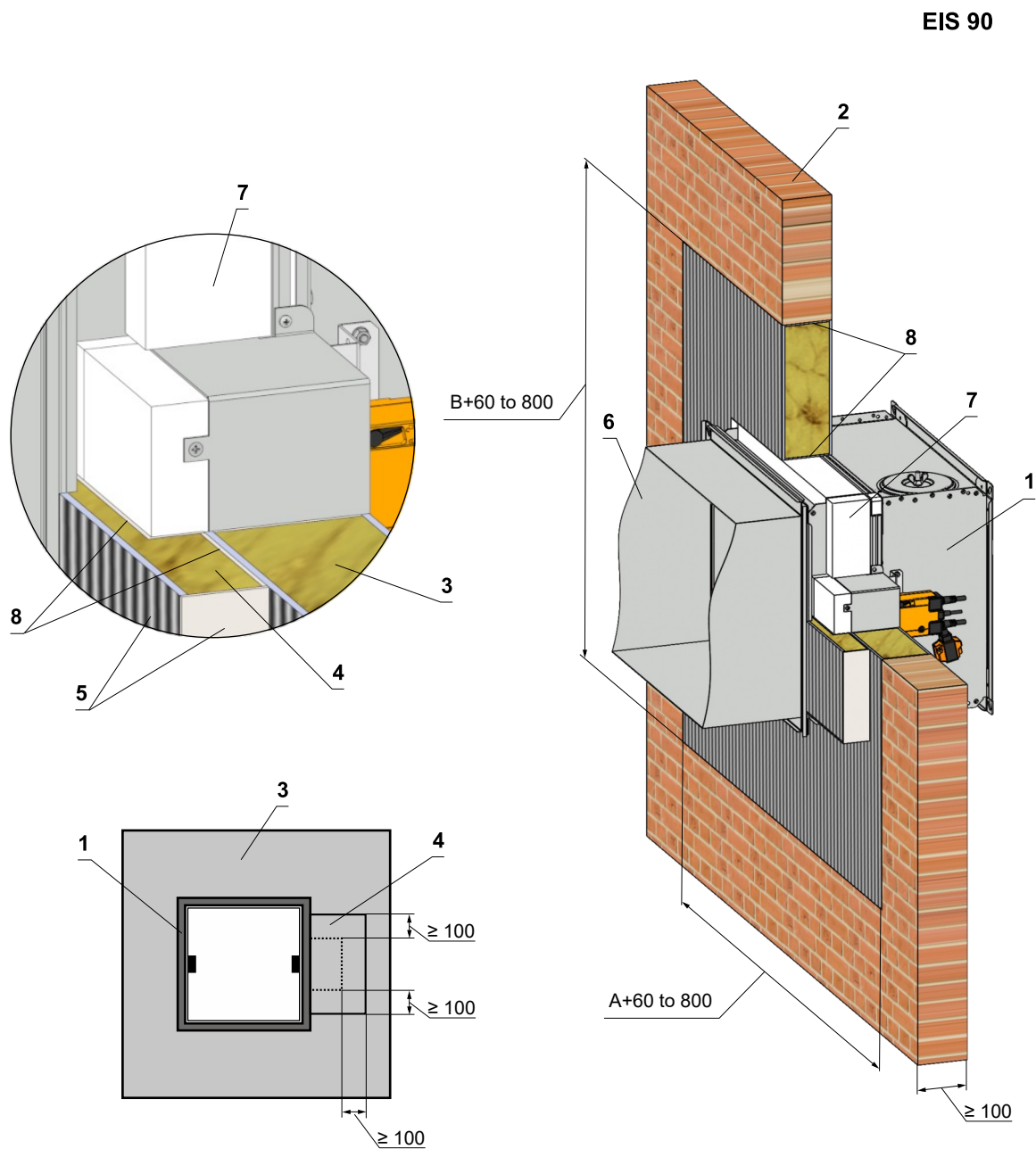
Used materials - example:

Position:

- 1 Fire damper
- 2 Solid wall construction
- 3 Mineral stone wool min. density 140 kg/m<sup>3</sup>
- 4 Fire protection mastic min. thickness 1 mm
- 5 Cement lime plate min. thickness 15 mm min. density 870 kg/m<sup>3</sup>

- 3 Promapyr, Rockwool Steprock HD, Hilti CFS-CT B 1S 140/50
- 4 Promastop - P, K, Hilti CFS-CT
- 5 Promatect - H

Fig. 32 Solid wall construction - Ablative Coated Batt



Position:

- 1 Fire damper
- 2 Solid wall construction
- 3 Fire resistant board
- 4 Additional drive cover insulation with fire resistant board
- 5 Fire stop coating thickness 1 mm
- 6 Duct
- 7 Protective cladding boards - (not part of the damper) but must be used as part of the penetration filling. It can be ordered from MANDÍK as an accessory.
- 8 Fire resistant mastic - fill the gap on both sides of the fire separation construction and around the perimeter of penetration and damper body.

Used materials - example:

- 3 Hilti CFS-CT B 1S 140/50
- 4 Hilti CFS-CT B 1S 140/50
- 5 Hilti CFS-CT
- 7 PROMATECT-MST, th. 30 mm
- 8 Hilti CFS-S ACR

5.3. Installation outside solid wall construction

Fig. 33 Outside solid wall construction - mineral wool - mortar or gypsum

**Minimum and maximum distance between the wall and fire damper when installation remote from the wall is unlimited.** **EIS 60**

**Position:**

- 1 Fire damper
- 2 Solid wall construction
- 3 Mortar or gypsum
- 4 Insulation board made of stone wool, with a surface treatment of aluminum foil, density 66 kg/m<sup>3</sup>
- 5 Duct
- 6 Apply ISOVER Protect BSK glue on the insulation and stick it to the fire separation construction \*\*\*

**Used materials - example:\*\***

- 4 Isover Ultimate Protect SLAB 4.0, th. 80 mm ALU1

**\*\*** Insulation materials can be replaced by another approved fire sealing system with equivalent properties.  
The maximum distance of the fire damper from the structure is not limited.

**\*\*\*** When installing the insulation, follow the ISOVER manufacturer's instructions.  
The duct at the point of penetration does not have to be anchored to the fire wall construction, see chapter 6.

Fig. 34 Outside solid wall construction - mineral wool - stuffing box and fire protection mastic

**Minimum and maximum distance between the wall and fire damper when installation remote from the wall is unlimited.** **EIS 60**

**Position:**

- 1 Fire damper
- 2 Solid wall construction
- 3 Stuffing box (mineral stone wool min. density 140 kg/m<sup>3</sup>)
- 4 Fire protection mastic min. thickness 1 mm
- 5 Insulation board made of stone wool, with a surface treatment of aluminum foil, density 66 kg/m<sup>3</sup>
- 6 Duct
- 7 Apply ISOVER Protect BSK glue on the insulation and stick it to the fire separation construction \*\*\*

**Used materials - example:\*\***

- 3 Promapyr, Rockwool Steprock HD, Hilti CFS-CT B 1S 140/50
- 4 Promastop - P, K, Hilti CFS-CT
- 5 Isover Ultimate Protect SLAB 4.0, th. 80 mm ALU1

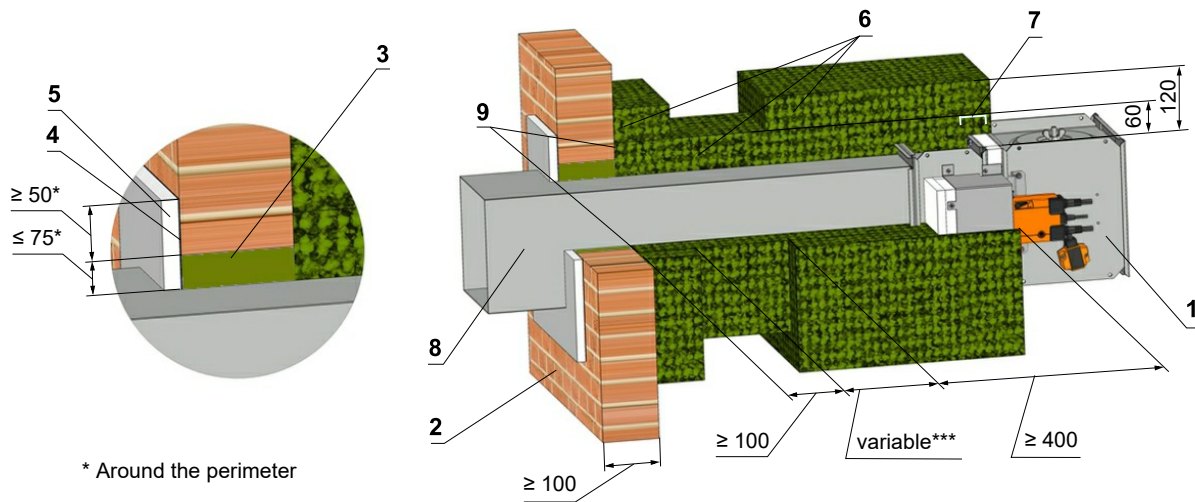
**\*\*** Insulation materials can be replaced by another approved fire sealing system with equivalent properties.  
The maximum distance of the fire damper from the structure is not limited.

**\*\*\*** When installing the insulation, follow the ISOVER manufacturer's instructions.  
The duct at the point of penetration must be anchored to the fire wall construction, see chapter 6.

Fig. 35 Outside solid wall construction - mineral wool, stuffing box, fire protection mastic and cement lime plate

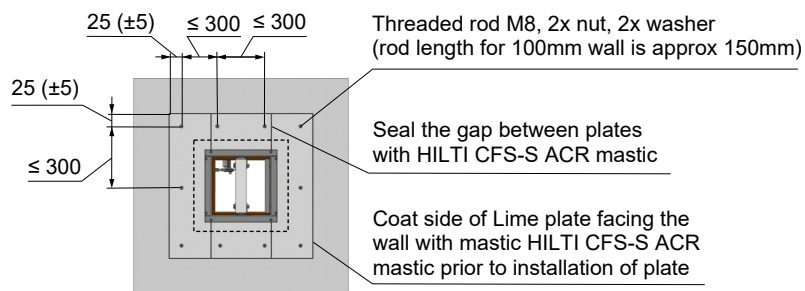
Minimum and maximum distance between the wall and fire damper when installation remote from the wall is unlimited.

EIS 90



\* Around the perimeter

Ensure symmetry with rod location



Screws has to be fixed in wall/ceiling construction.  
(If it is needed use steel bracket).

Position:

- 1 Fire damper
- 2 Solid wall construction
- 3 Mineral stone wool min. density 140 kg/m<sup>3</sup>
- 4 Fire protection mastic min. thickness 1 mm
- 5 Cement lime plate min. thickness 15 mm (min. density 870 kg/m<sup>3</sup>)
- 6 Stone wool bound with use of an organic resin with crushed stone as a refrigerant, min. density 300 kg/m<sup>3</sup> and min. thickness 60 mm
- 7 Steel sheet reinforcement U25x40x25 placed between layers of stone wool \*\*\*\*
- 8 Duct
- 9 Apply Rockwool Firepro glue on the insulation and stick it to the fire separation construction \*\*\*\*\*

Used materials - example:\*\*

- 3 Promapyr, Rockwool Steprock HD, Hilti CFS-CT B 1S 140/50
- 4 Promastop - P, K, Hilti CFS-CT
- 5 Promatect - H
- 6 Rockwool Conlit Ductrock EIS 90

\*\* Stuffing box, fire protection mastic, cement lime plate and insulation materials can be replaced by another approved fire sealing system for damper installation with equivalent material properties.

\*\*\* Depends on the distance of the flap from the construction, when the maximum distance from the construct is not limited and according to EN 15882-2 must use the required number of hinges according to EN 13366-1:2014.

\*\*\*\* For installation methods outside a construction, when the damper size is A ≥ 800 mm, it is necessary to use the VRM-Q reinforcing frame, see Fig.47. Assembly - reinforcing frame U25x40x25 see Fig.48.

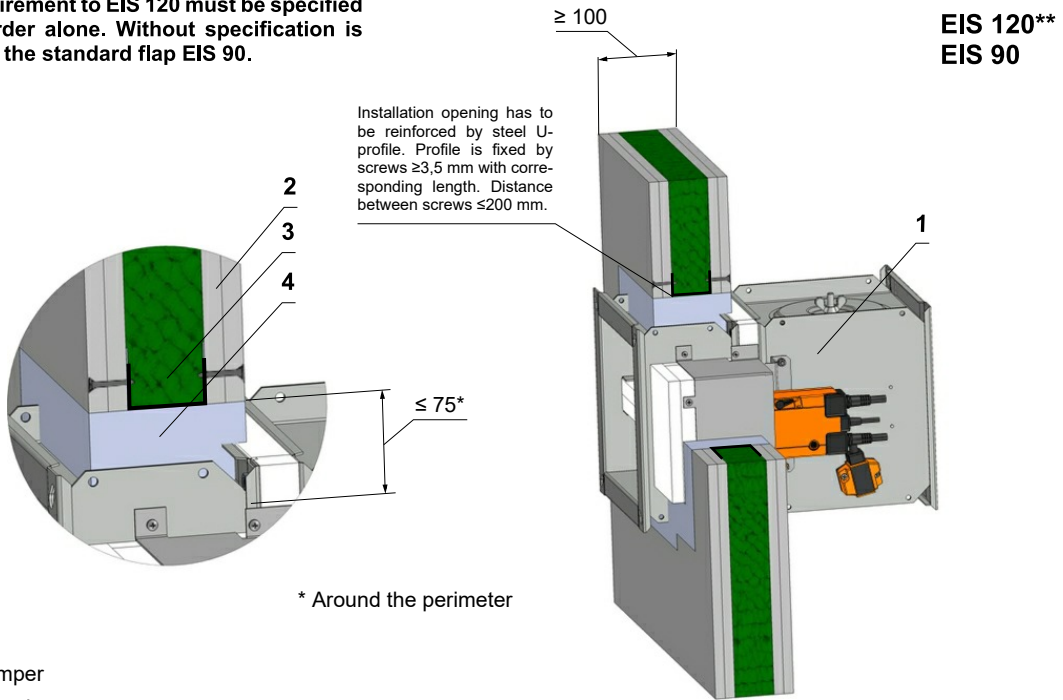
\*\*\*\*\* When installing the insulation, follow the Rockwool manufacturer's instructions.

The duct at the point of penetration must be anchored to the fire wall construction, see chapter 6.

5.4. Installation in gypsum wall construction

Fig. 36 Gypsum wall construction - mortar or gypsum

\*\* The requirement to EIS 120 must be specified in the order alone. Without specification is supplied the standard flap EIS 90.



\* Around the perimeter

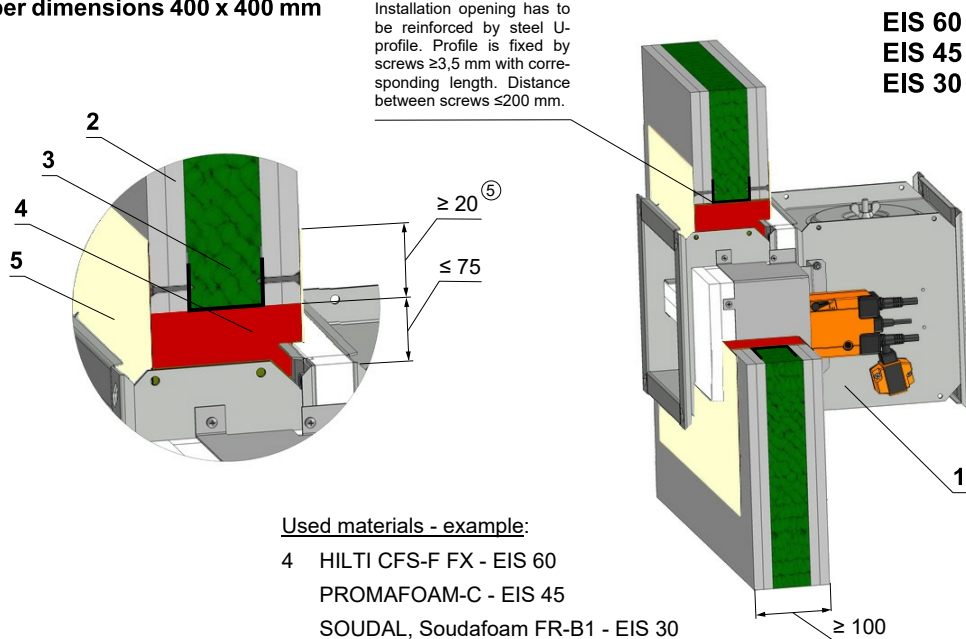
Position:

- 1 Fire damper
- 2 Gypsum plate
- 3 Mineral wool (type depending on the type of construction)
- 4 Mortar or gypsum

Fig. 37 Gypsum wall construction - fire protection foam with stucco plaster

Maximal damper dimensions 400 x 400 mm

Installation opening has to be reinforced by steel U-profile. Profile is fixed by screws ≥3,5 mm with corresponding length. Distance between screws ≤200 mm.



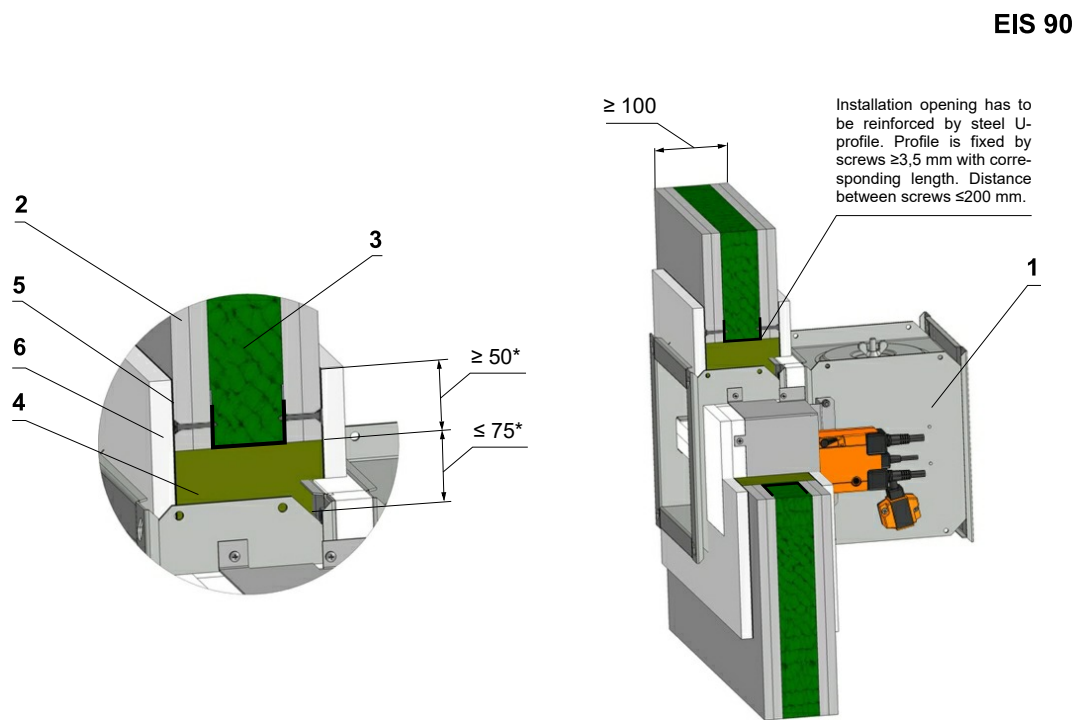
Used materials - example:

- 4 HILTI CFS-F FX - EIS 60
- PROMAFOAM-C - EIS 45
- SOULDAL, Soudafoam FR-B1 - EIS 30
- DenBraven, Fire protection foam - EIS 30

Position:

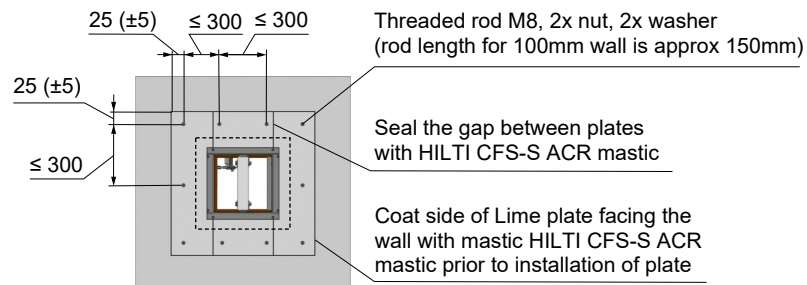
- 1 Fire damper
- 2 Gypsum plate
- 3 Mineral wool (type depending on the type of construction)
- 4 Fire protection foam
- 5 Stucco plaster

Fig. 38 Gypsum wall construction - stuffing box, fire protection mastic and cement lime plate



\* Around the perimeter

Ensure symmetry with rod location



Screws has to be fixed in wall/ceiling construction.  
(If it is needed use steel bracket).

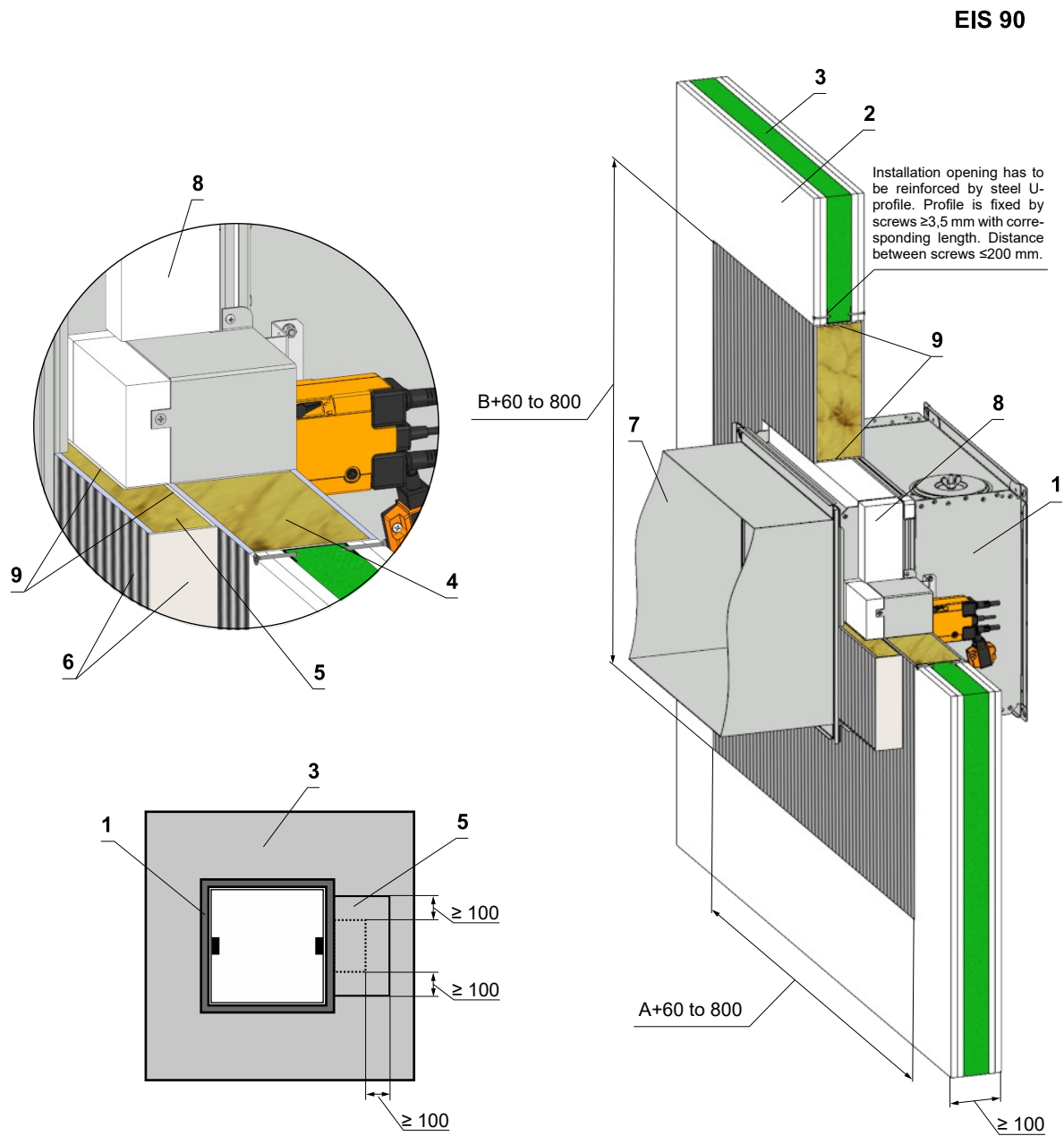
Used materials - example:

Position:

- |   |   |   |  |
|---|---|---|--|
| 1 | Fire damper   | 4 | Promapyr, Rockwool Steprock HD, Hilti CFS-CT B 1S 140/50 |
| 2 | Gypsum plate  | 5 | Promastop - P, K, Hilti CFS-CT                           |
| 3 | Mineral wool (type depending on the type of construction)                       | 6 | Promatect - H  |
| 4 | Mineral stone wool min. density 140 kg/m <sup>3</sup>                           |   |  |
| 5 | Fire protection mastic min. thickness 1 mm                                      |   |  |
| 6 | Cement lime plate min. thickness 15 mm<br>(min. density 870 kg/m <sup>3</sup> ) |   |  |



Fig. 39 Gypsum wall construction - Ablative Coated Batt



Position:

- 1 Fire damper
- 2 Gypsum plate
- 3 Mineral wool (type depending on the type of construction)
- 4 Fire resistant board
- 5 Additional drive cover insulation with fire resistant board
- 6 Fire stop coating thickness 1 mm
- 7 Duct
- 8 Protective cladding boards - (not part of the damper) but must be used as part of the penetration filling. It can be ordered from MANDIK as an accessory.
- 9 Fire resistant mastic - fill the gap on both sides of the fire separation construction and around the perimeter of penetration and damper body.

Used materials - example:

- 4 Hilti CFS-CT B 1S 140/50
- 5 Hilti CFS-CT B 1S 140/50
- 6 Hilti CFS-CT
- 8 PROMATECT-MST, th. 30 mm
- 9 Hilti CFS-S ACR

5.5. Installation outside gypsum wall construction

Fig. 40 Outside gypsum wall construction - mineral wool - mortar or gypsum

Minimum and maximum distance between the wall and fire damper when installation remote from the wall is unlimited.

EIS 60

Installation opening has to be reinforced by steel U-profile. Profile is fixed by screws  $\geq 3,5$  mm with corresponding length. Distance between screws  $\leq 200$  mm.

Position:

- 1 Fire damper
- 2 Gypsum plate
- 3 Mineral wool (type depending on the type of construction)
- 4 Mortar or gypsum
- 5 Insulation board made of stone wool, with a surface treatment of aluminum foil, density  $66 \text{ kg/m}^3$
- 6 Duct
- 7 Apply ISOVER Protect BSK glue on the insulation and stick it to the fire separation construction \*\*\*

**Used materials - example:\*\***

5 Isover Ultimate Protect SLAB 4.0, th. 80 mm ALU1

\*\* Insulation materials can be replaced by another approved fire sealing system with equivalent properties.  
The maximum distance of the fire damper from the structure is not limited.

\*\*\* When installing the insulation, follow the ISOVER manufacturer's instructions.

The duct at the point of penetration does not have to be anchored to the fire wall construction, see chapter 6.

Fig. 41 Outside gypsum wall construction - mineral wool - stuffing box and fire protection mastic

Minimum and maximum distance between the wall and fire damper when installation remote from the wall is unlimited.

EIS 60

Installation opening has to be reinforced by steel U-profile. Profile is fixed by screws  $\geq 3,5$  mm with corresponding length. Distance between screws  $\leq 200$  mm.

Position:

- 1 Fire damper
- 2 Gypsum plate
- 3 Mineral wool (type depending on the type of construction)
- 4 Stuffing box (mineral stone wool min. density  $140 \text{ kg/m}^3$ )
- 5 Fire protection mastic min. thickness 1 mm
- 6 Insulation board made of stone wool, with a surface treatment of aluminum foil, density  $66 \text{ kg/m}^3$
- 7 Duct
- 8 Apply ISOVER Protect BSK glue on the insulation and stick it to the fire separation construction \*\*\*

**Used materials - example:\*\***

4 Promapyr, Rockwool Steprock HD, Hilti CFS-CT B 1S 140/50  
5 Promastop - P, K, Hilti CFS-CT  
6 Isover Ultimate Protect SLAB 4.0, th. 80 mm ALU1

\*\* Insulation materials can be replaced by another approved fire sealing system with equivalent properties.  
The maximum distance of the fire damper from the structure is not limited.

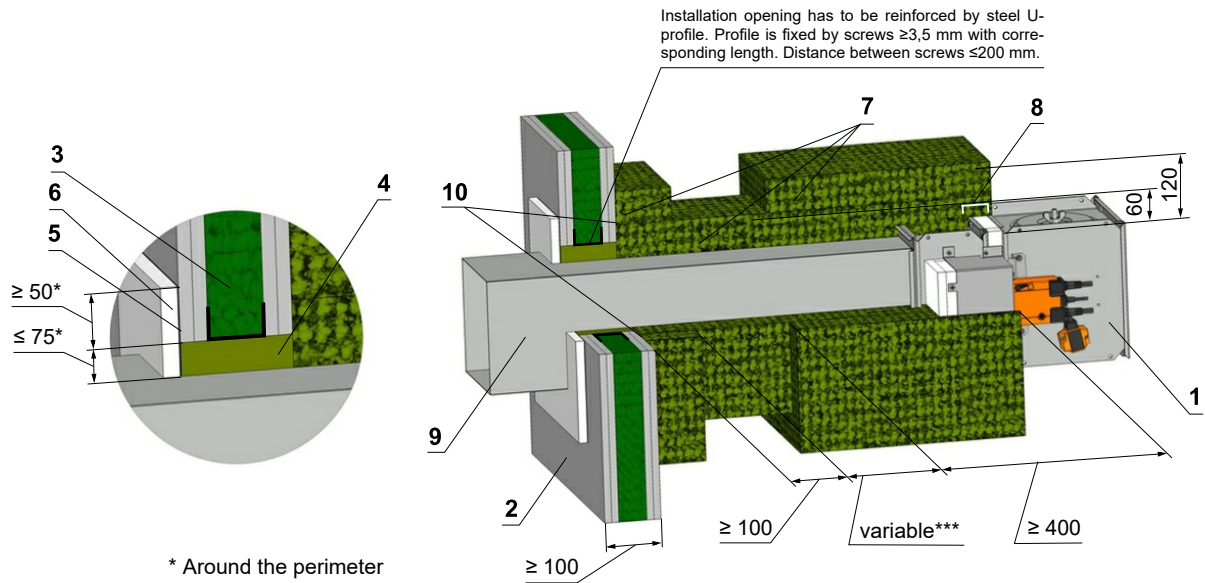
\*\*\* When installing the insulation, follow the ISOVER manufacturer's instructions.

The duct at the point of penetration must be anchored to the fire wall construction, see chapter 6.

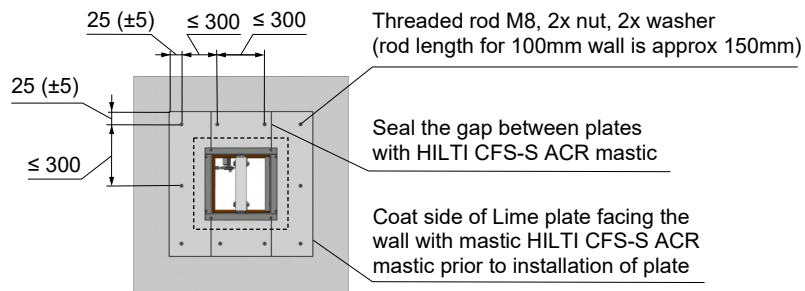
Fig. 42 Outside gypsum wall construction - mineral wool

Minimum and maximum distance between the wall and fire damper when installation remote from the wall is unlimited.

EIS 90



Ensure symmetry with rod location



Screws has to be fixed in wall/ceiling construction. (If it is needed use steel bracket).

Position:

- 1 Fire damper
- 2 Gypsum plate
- 3 Mineral wool (type depending on the type of construction)
- 4 Mineral stone wool min. density 140 kg/m<sup>3</sup>
- 5 Fire protection mastic min. thickness 1 mm
- 6 Cement lime plate min. thickness 15 mm (min. density 870 kg/m<sup>3</sup>)
- 7 Stone wool bound with use of an organic resin with crushed stone as a refrigerant, min. density 300 kg/m<sup>3</sup> and min. thickness 60 mm
- 8 Steel sheet reinforcement U25x40x25 placed between layers of stone wool \*\*\*\*
- 9 Duct
- 10 Apply Rockwool Firepro glue on the insulation and stick it to the fire separation construction \*\*\*\*\*

Used materials - example:\*\*

- 4 Promapyr. Rockwool Steprock HD. Hilti CFS-CT C 1S 140/50
- 5 Promastop - P, K, Hilti CFS-CT
- 6 Promatect - H
- 7 Rockwool Conlit Ductrock EIS 90

\*\* Stuffing box, fire protection mastic, cement lime plate and insulation materials can be replaced by another approved fire sealing system for damper installation with equivalent material properties.

\*\*\* Depends on the distance of the flap from the construction, when the maximum distance from the construct is not limited and according to EN 15882-2 must use the required number of hinges according to EN 13366-1:2014.

\*\*\*\* For installation methods outside a construction, when the damper size is  $A \geq 800$  mm, it is necessary to use the VRM-Q reinforcing frame, see Fig.47. Assembly - reinforcing frame U25x40x25 see Fig.48.

\*\*\*\*\* When installing the insulation, follow the Rockwool manufacturer's instructions.

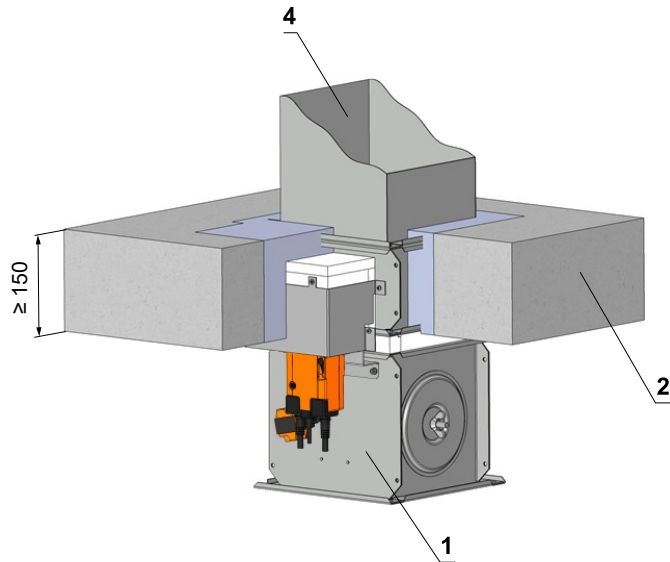
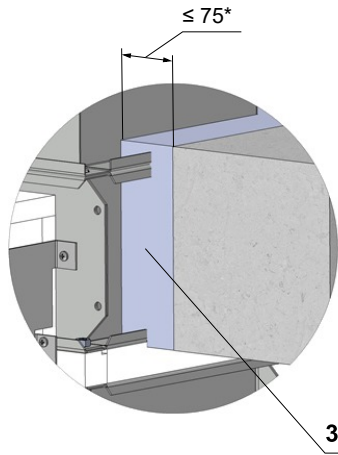
The duct at the point of penetration must be anchored to the fire wall construction, see chapter 6.

5.6. Installation in solid ceiling construction

Fig. 43 Solid ceiling construction - mortar or gypsum

\*\* The requirement to EIS 120 must be specified in the order alone. Without specification is supplied the standard flap EIS 90.

EIS 120\*\*  
EIS 90



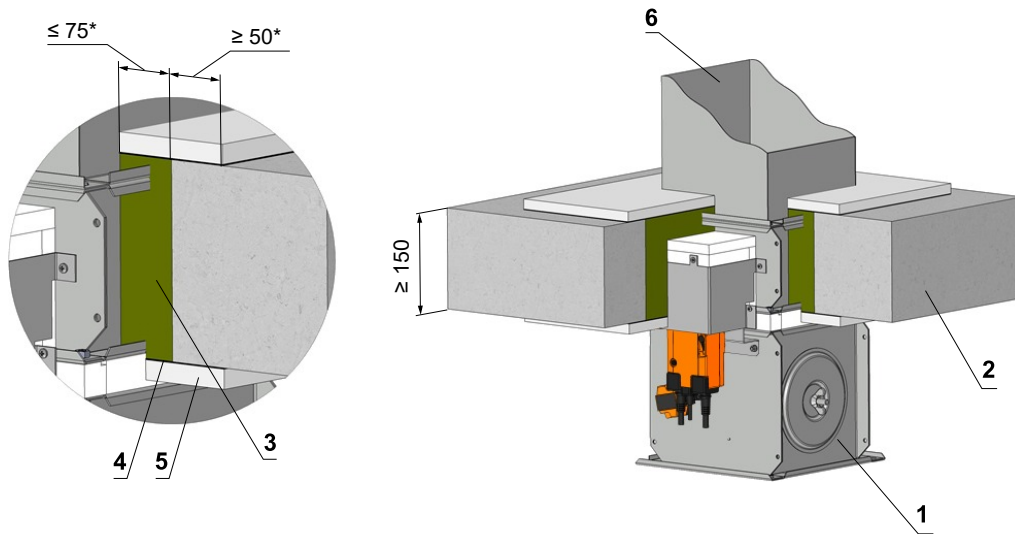
Position:

- 1 Fire damper
- 2 Solid ceiling construction
- 3 Mortar or gypsum
- 4 Duct

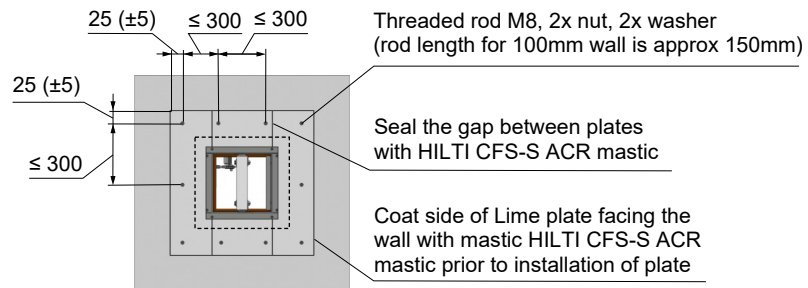
\* Around the perimeter

Fig. 44 Solid ceiling construction - stuffing box, fire protection mastic and cement lime plate

EIS 90



Ensure symmetry with rod location



Screws has to be fixed in wall/ceiling construction.  
(If it is needed use steel bracket).

\* Around the perimeter

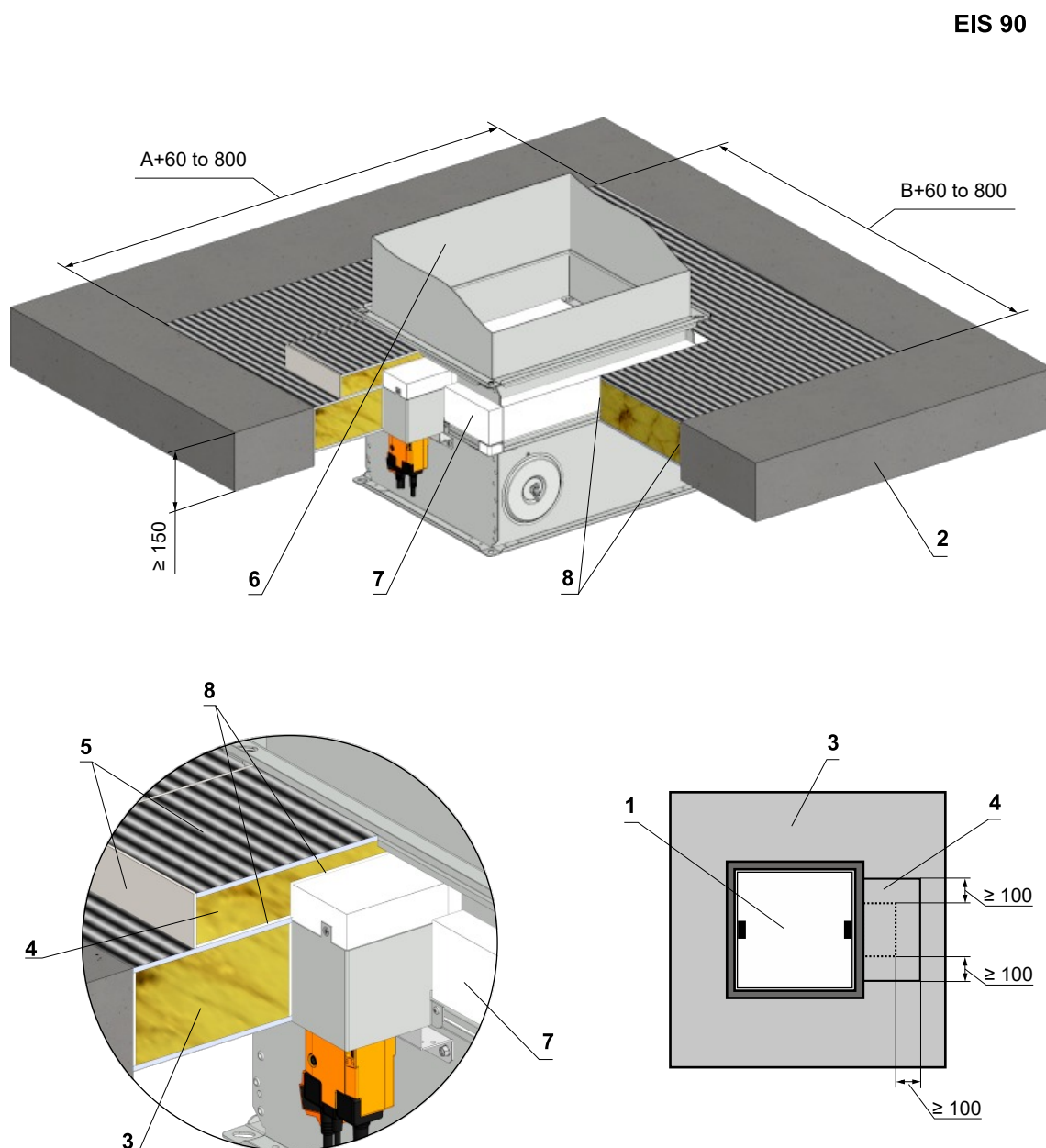
Used materials - example:

- 3 Promapyr, Rockwool Steprock HD, Hilti CFS-CT B 1S 140/50
- 4 Promastop - P, K, Hilti CFS-CT
- 5 Promatect - H

Position:

- 1 Fire damper
- 2 Solid ceiling construction
- 3 Stuffing box (mineral stone wool min. density 140 kg/m<sup>3</sup>)
- 4 Fire protection mastic min. thickness 1 mm
- 5 Cement lime plate min. thickness 15 mm, min. density 870 kg/m<sup>3</sup>
- 6 Duct

Fig. 45 Solid ceiling construction - Ablative Coated Batt



Position:

- 1 Fire damper
- 2 Solid ceiling construction
- 3 Fire resistant board
- 4 Additional drive cover insulation with Fire resistant board
- 5 Fire stop coating thickness 1 mm
- 6 Duct
- 7 Protective cladding boards - (not part of the damper) but must be used as part of the penetration filling. It can be ordered from MANDÍK as an accessory.
- 8 Fire resistant mastic - fill the gap on both sides of the fire separation construction and around the perimeter of penetration and damper body.

Used materials - example:

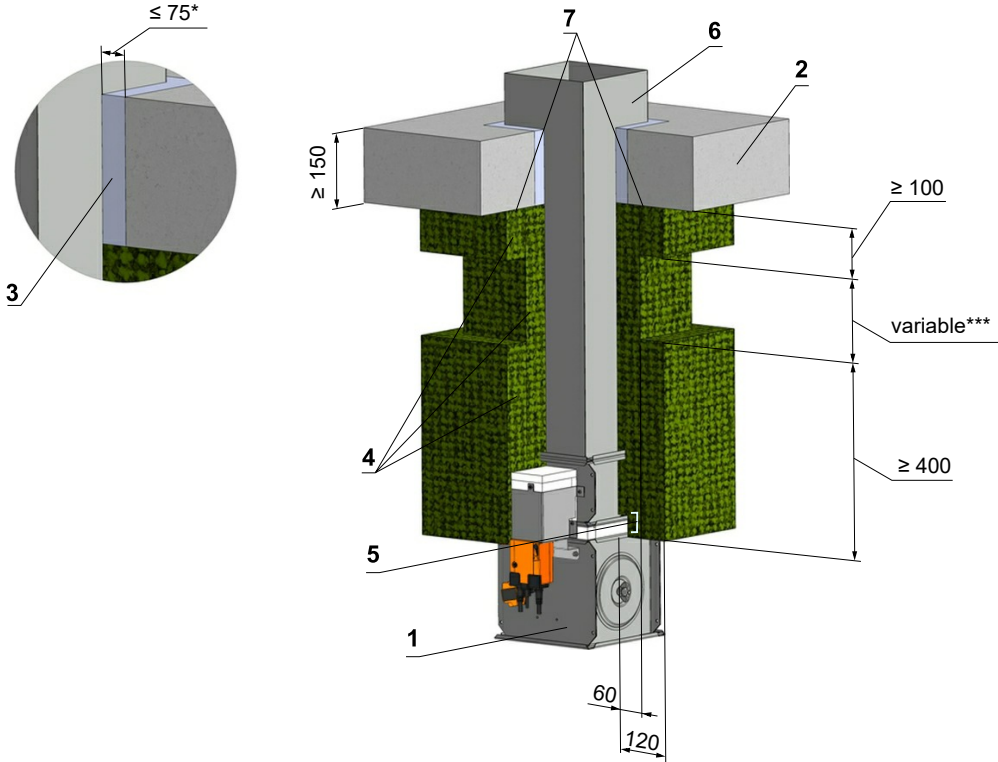
- 3 Hilti CFS-CT B 1S 140/50
- 4 Hilti CFS-CT B 1S 140/50
- 5 Hilti CFS-CT
- 7 PROMATECT-MST, th. 30 mm
- 8 Hilti CFS-S ACR

5.7. Installation outside solid ceiling construction

Fig. 46 Outside solid ceiling construction - mineral wool - mortar or gypsum

Minimum and maximum distance between the wall and fire damper when installation remote from the wall is unlimited.

EIS 90



\* Around the perimeter

Used materials - example:\*\*

4 Rockwool Conlit Ductrock EIS 90

Position:

- 1 Fire damper
- 2 Solid ceiling construction
- 3 Mortar or gypsum
- 4 Stone wool bound with use of an organic resin with crushed stone as a refrigerant, min. density 300 kg/m<sup>3</sup> and min. thickness 60 mm
- 5 Steel sheet reinforcement U25x40x25 placed between layers of stone wool \*\*\*\*
- 6 Duct
- 7 Apply Rockwool Firepro glue on the insulation and stick it to the fire separation construction \*\*\*\*\*

\*\* Stuffing box, fire protection mastic, cement lime plate and insulation materials can be replaced by another approved fire sealing system for damper installation with equivalent material properties.

\*\*\* Depends on the distance of the flap from the construction, when the maximum distance from the construct is not limited and according to EN 15882-2 must use the required number of hinges according to EN 13366-1:2014..

\*\*\*\* For installation methods outside a construction, when the damper size is A ≥ 800 mm, it is necessary to use the VRM-Q reinforcing frame, see Fig.47. Assembly - reinforcing frame U25x40x25 see Fig.48.

\*\*\*\*\* When installing the insulation, follow the Rockwool manufacturer's instructions.

The duct at the point of penetration does not have to be anchored to the fire wall construction, see chapter 6.

5.8. VRM-Q reinforcing frame

For dampers with  $A \geq 800$  and damper placement outside wall construction is necessary to use reinforcement VRM-Q.

Fig. 47 Fixing of reinforcement to damper body

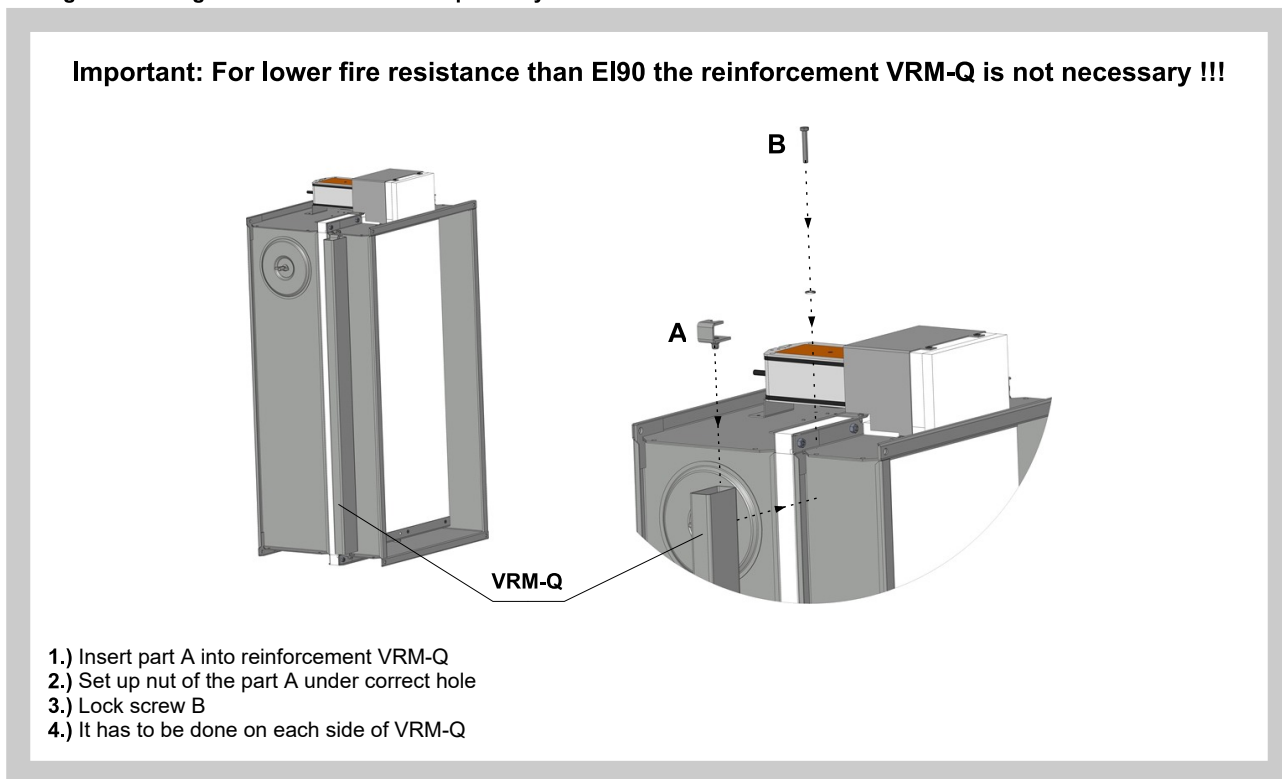
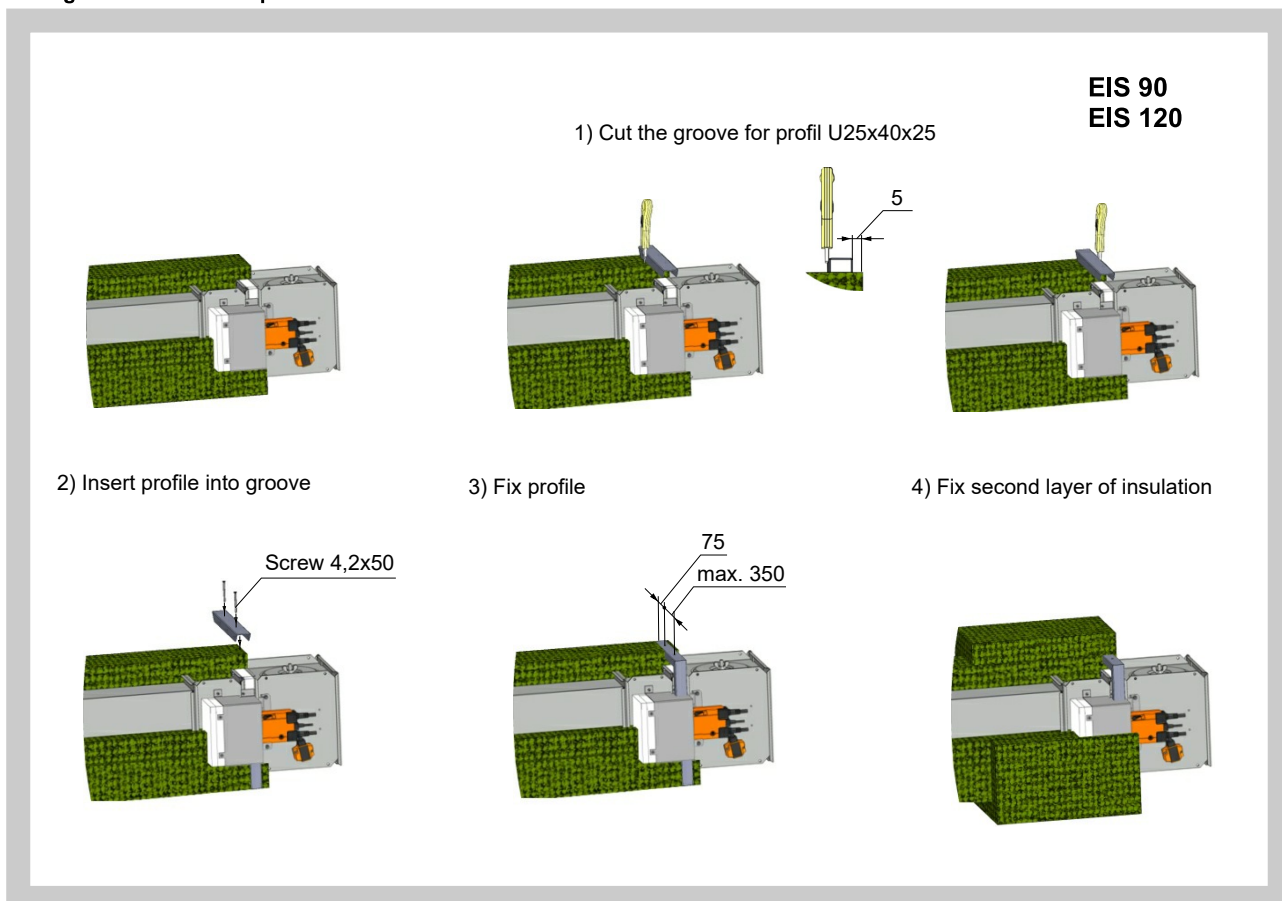


Fig. 48 Installation procedure

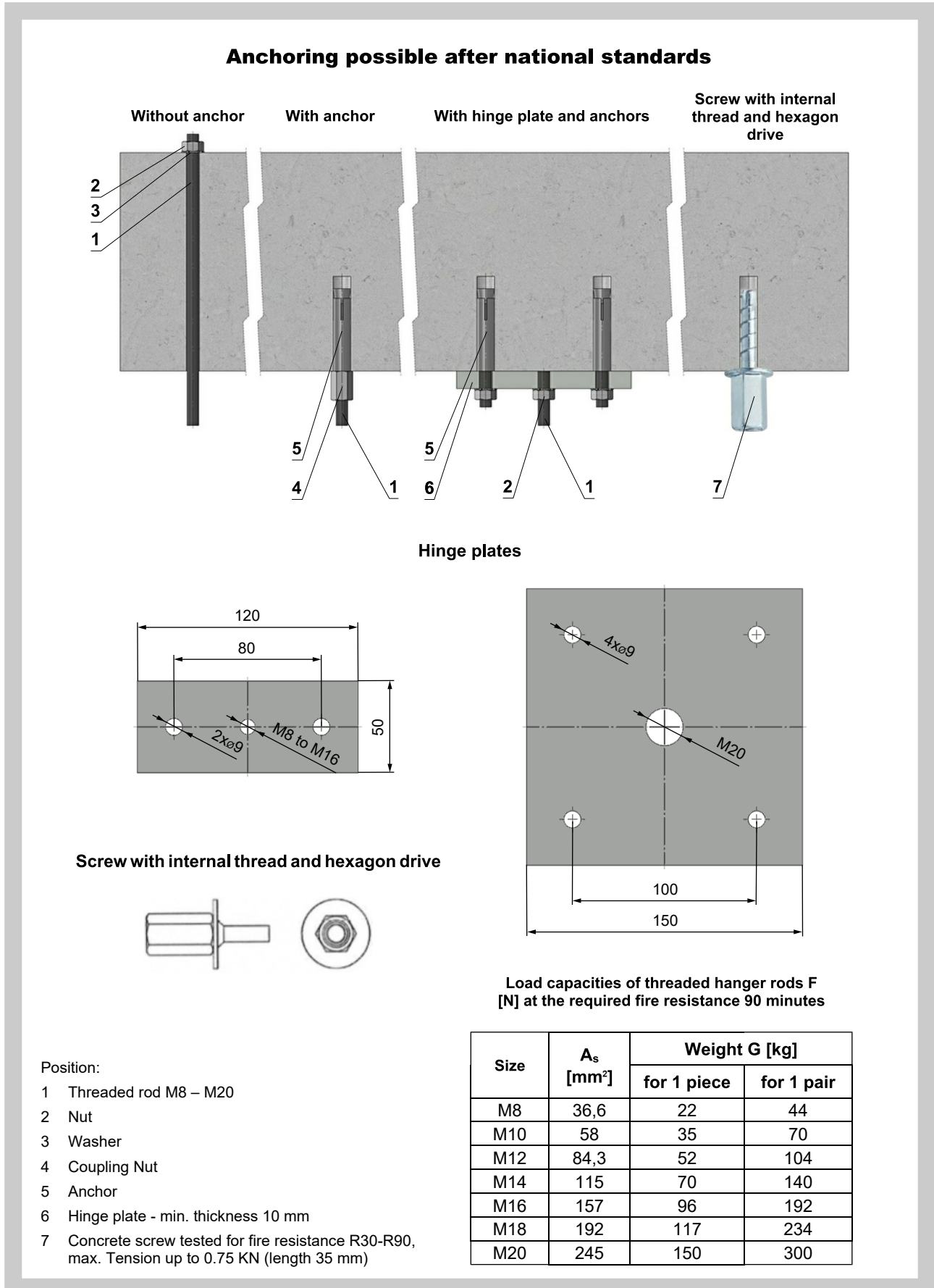




6. Suspension systems

6.1. Mounting to the ceiling wall

Fig. 49 Mounting to the ceiling wall



**6.2. Horizontal installation**

Damper assembly procedures must be done so as all load transfer from the fire separating constructions to the damper body is absolutely excluded. Back-to-back air-conditioning piping must be hung or supported so as all load transfer from the back-to-back piping to the damper is absolutely excluded.

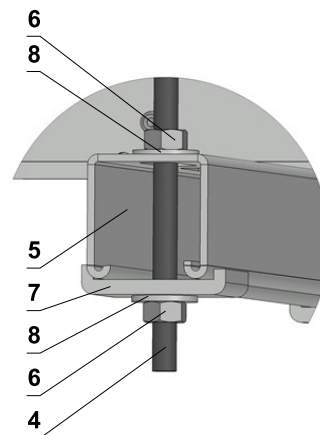
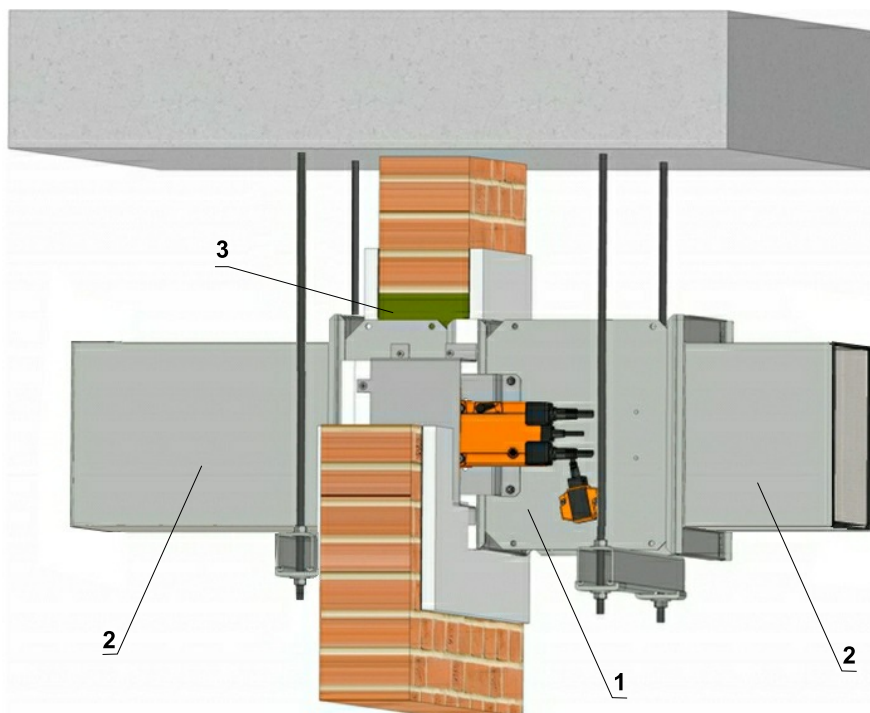
On Fig. 50 is typical mounting situation as an example.

Threaded rods longer than 1,5 m require fire-resistant insulation.

Threaded rod fixing to the ceiling construction - see fig. 49

**Fig. 50 Suspension - horizontal duct (soft padding - mineral wool + fire boards)**

**EIS 90**



Position:

- 1 Fire damper
- 2 Duct
- 3 Mineral wool
- 4 Threaded rod
- 5 Mounting rail
- 6 Nut
- 7 U - Washer
- 8 Washer

Examples of using materials: HILTI, SIKLA, MÜPRO etc.

**6.3. Vertical installation**

The damper must not be suspended or anchored. The duct must be anchored after national rules, like in fig. 51 - as an example. It can be suspended by using threaded rods and a mounting profiles. Load the suspension system depend on weight of the fire damper.

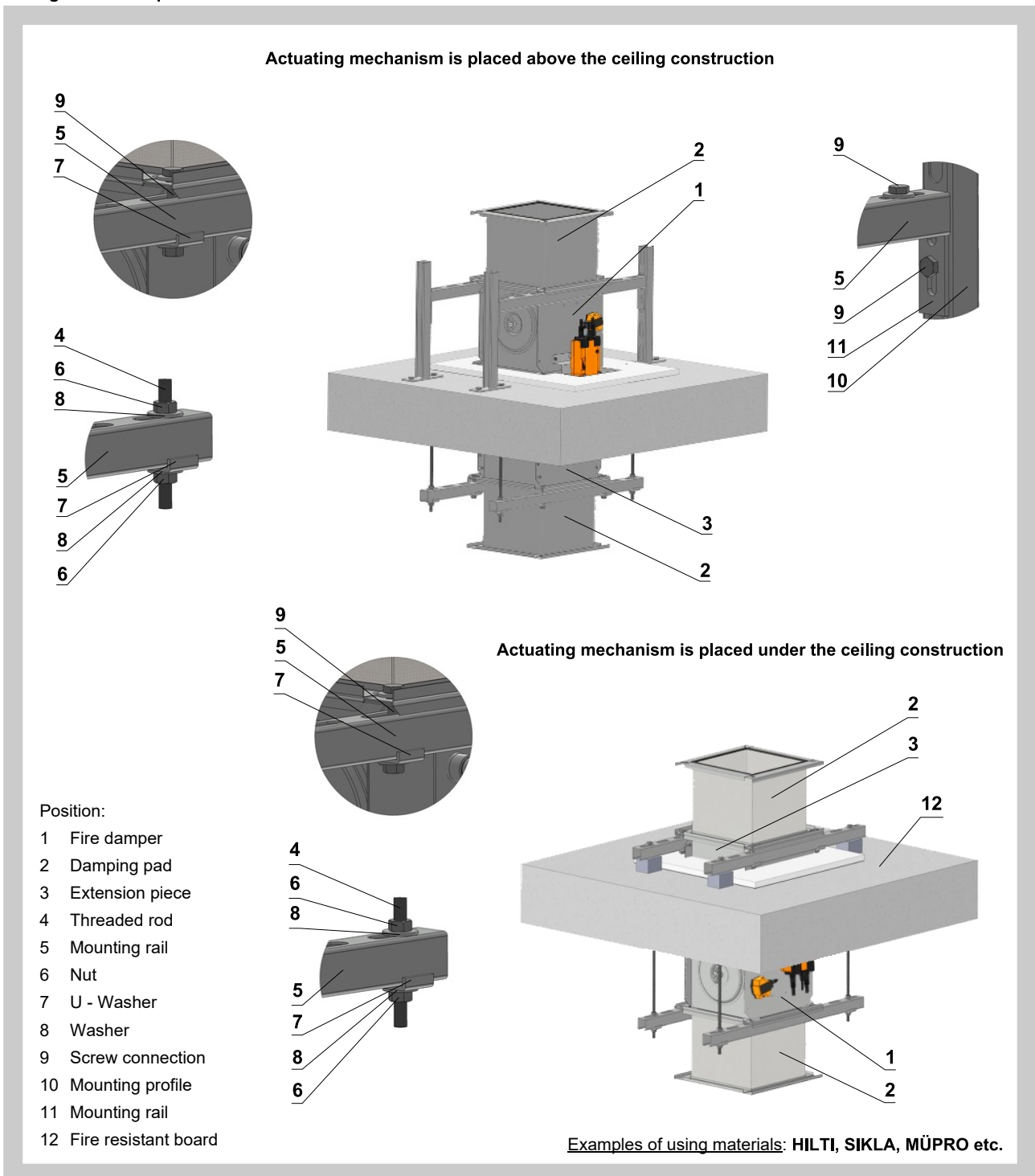
Damper can be suspended from the ceiling construction or supported above the ceiling construction.

Damper assembly procedures must be done so as all load transfer from the fire separating constructions to the damper body is absolutely excluded. Back-to-back air-conditioning piping must be hung or supported so as all load transfer from the back-to-back piping to the damper is absolutely excluded.

Threaded rods longer than 1,5 m require fire-resistant insulation.

Threaded rod fixing to the ceiling construction - see fig. 49

**Fig. 51 Suspension - vertical duct**



**6.4. Rectangular fire damper suspension remote from the wall - horizontal installation**

Fire dampers installed remote from the wall must be suspended.  
The duct must be suspended on both sides of damper after national rules.

Duct between fire damper and fire separating construction must be suspended by using threaded rods and mounting profiles, or another anchoring system according national standards. Load the suspension system depend on weight of the fire damper and duct system.

Max. length between two suspension systems is 1500 mm.

Damper assembly procedures must be done so as all load transfer from the fire separating constructions to the damper body is absolutely excluded. Back-to-back air-conditioning piping must be hung or supported so as all load transfer from the back-to-back piping to the damper is absolutely excluded.

Threaded rods longer than 1,5 m require fire-resistant insulation.

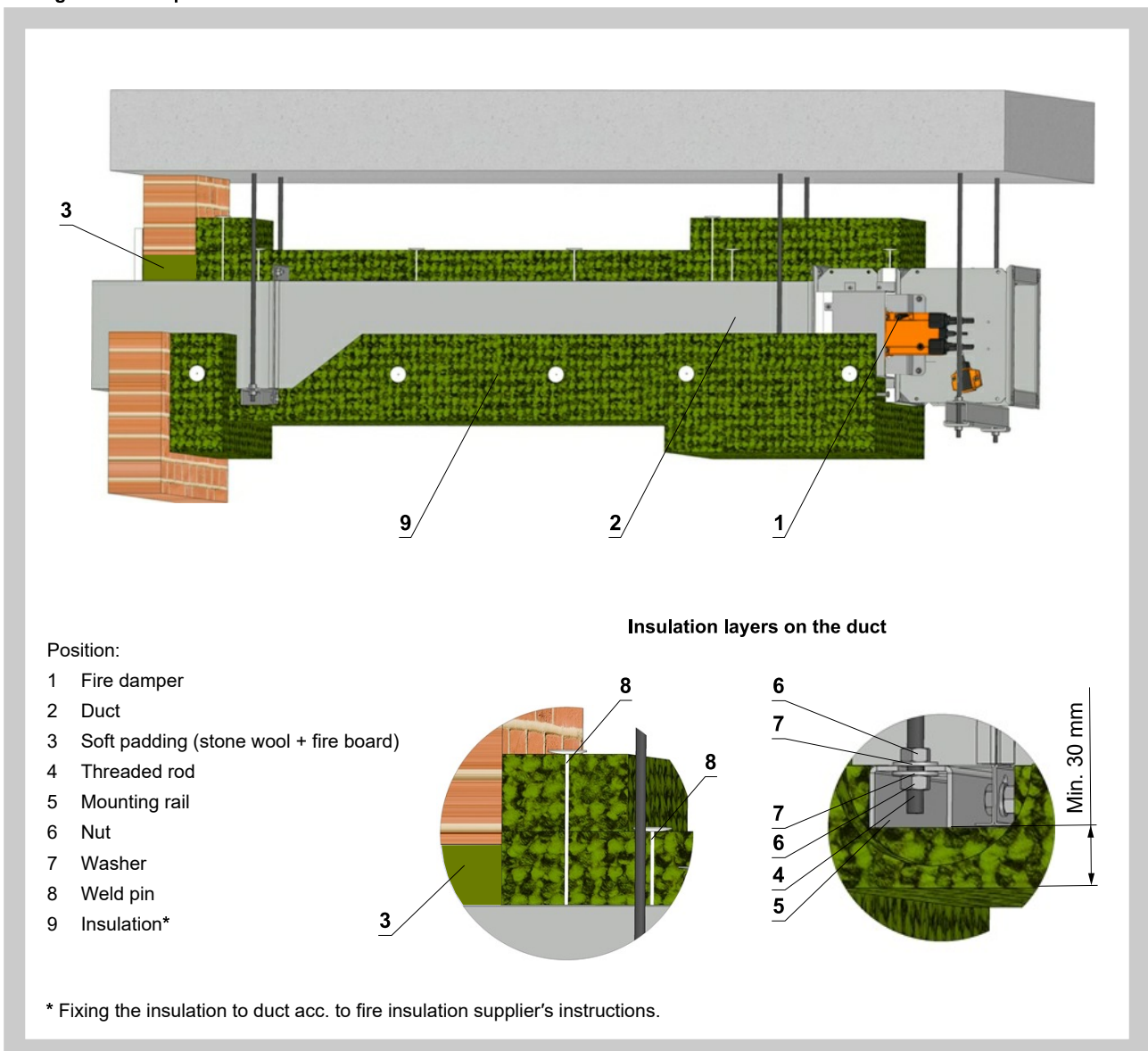
If the threaded rod is located inside the duct insulation, distance between threaded rod and duct is max 30 mm. If the treaded rod is located outside the duct isolation, distance between threaded rod and isolation is max. 40 mm. Thickness of the insulation under mounting profile must be min. 30 mm.

Threaded rod fixing to the ceiling construction - see fig. 49

The insulation boards are fastened to the duct.

For more information see documentation of insulation manufacturer.

**Fig. 52 Suspension remote from the wall - horizontal installation**



**III. TECHNICAL DATA**

**7. Pressure loss**

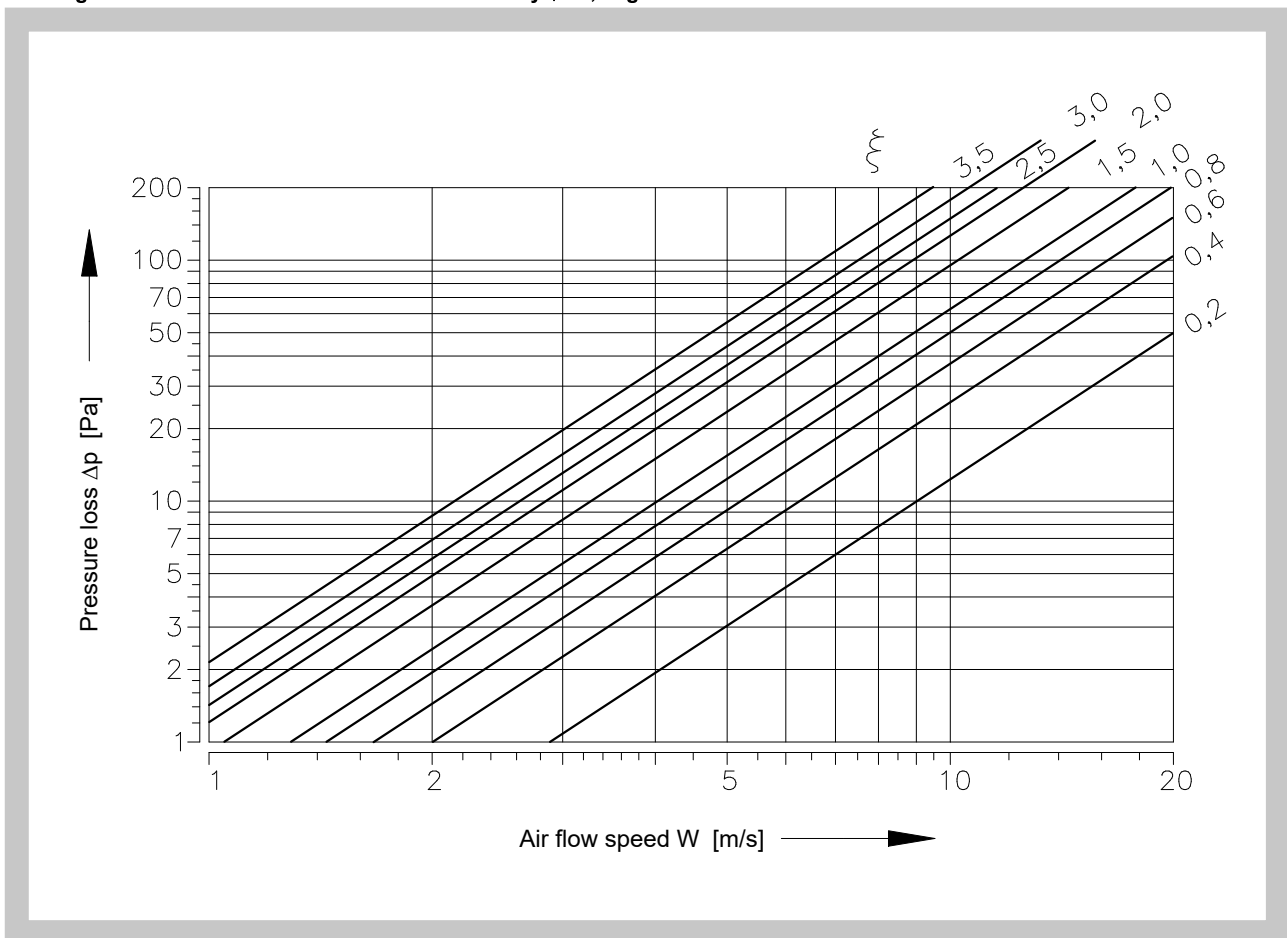
**7.1. Pressure loss calculation**

$$\Delta p = \xi \cdot \rho \cdot \frac{w^2}{2}$$

$\Delta p$	[Pa]	pressure loss
$w$	[m.s <sup>-1</sup> ]	air flow speed in nominal damper section
$\rho$	[kg.m <sup>-3</sup> ]	air density
$\xi$	[-]	coefficient of local pressure loss for the nominal damper section (see Tab. 8.1.1.)

**7.2. Determination of pressure loss by using diagram  $\rho = 1,2 \text{ kg.m}^{-3}$**

**Diagram 7.2.1. Pressure losses for air density  $\rho=1,2 \text{ kg.m}^{-3}$**



**8. Coefficient of local pressure loss**

**8.1. Coefficient of local pressure loss  $\xi$  (-)**

**Tab. 8.1.1. Coefficient of local pressure loss**

	<b>B</b>										
<b>A</b>	<b>180</b>	<b>200</b>	<b>225</b>	<b>250</b>	<b>280</b>	<b>300</b>	<b>315</b>	<b>355</b>	<b>400</b>	<b>450</b>	<b>500</b>
<b>180</b>	1,849	1,476	1,210	0,983	0,888	0,823	0,703	0,608	0,535	0,478	0,437
<b>200</b>	1,737	1,385	1,095	0,921	0,862	0,782	0,658	0,569	0,500	0,446	0,407
<b>225</b>	1,678	1,333	0,995	0,887	0,832	0,754	0,638	0,545	0,479	0,430	0,393
<b>250</b>	1,613	1,286	0,978	0,859	0,805	0,722	0,613	0,524	0,462	0,414	0,381
<b>280</b>	1,538	1,218	0,954	0,814	0,768	0,682	0,583	0,499	0,438	0,395	0,358
<b>300</b>	1,482	1,178	0,926	0,772	0,722	0,642	0,549	0,475	0,422	0,372	0,342
<b>315</b>	1,415	1,124	0,894	0,743	0,682	0,598	0,528	0,456	0,400	0,356	0,325
<b>355</b>	1,359	1,079	0,852	0,713	0,635	0,573	0,506	0,436	0,383	0,341	0,311
<b>400</b>	1,312	1,041	0,811	0,687	0,618	0,562	0,487	0,420	0,368	0,328	0,299
<b>450</b>	1,271	1,009	0,798	0,665	0,602	0,533	0,471	0,406	0,356	0,317	0,289
<b>500</b>	1,240	0,983	0,773	0,648	0,592	0,526	0,459	0,395	0,346	0,308	0,281
<b>550</b>	1,225	0,971	0,752	0,638	0,586	0,522	0,451	0,389	0,341	0,306	0,278
<b>560</b>	1,211	0,960	0,744	0,632	0,572	0,519	0,447	0,385	0,337	0,300	0,274
<b>600</b>	1,198	0,945	0,738	0,626	0,568	0,507	0,441	0,381	0,334	0,297	0,270
<b>630</b>	1,184	0,938	0,728	0,617	0,565	0,493	0,437	0,376	0,329	0,293	0,267
<b>650</b>	1,173	0,928	0,711	0,610	0,544	0,490	0,431	0,371	0,324	0,289	0,266
<b>700</b>	1,165	0,922	0,705	0,609	0,539	0,489	0,429	0,369	0,323	0,288	0,263
<b>710</b>	1,160	0,919	0,697	0,604	0,535	0,488	0,427	0,368	0,322	0,287	0,261
<b>750</b>	1,150	0,911	0,691	0,600	0,530	0,482	0,422	0,363	0,318	0,284	0,258
<b>800</b>	1,140	0,903	0,686	0,593	0,523	0,475	0,419	0,361	0,316	0,281	0,256
<b>900</b>	1,122	0,888	0,674	0,583	0,517	0,467	0,412	0,355	0,310	0,276	0,252
<b>1000</b>	1,108	0,877	0,666	0,576	0,509	0,453	0,407	0,350	0,306	0,273	0,248
<b>1100</b>	1,095	0,867	0,657	0,569	0,498	0,443	0,402	0,345	0,302	0,269	0,245
<b>1250</b>	1,084	0,857	0,643	0,562	0,486	0,438	0,397	0,342	0,299	0,266	0,242
<b>1400</b>	1,073	0,849	0,632	0,557	0,478	0,436	0,393	0,338	0,296	0,263	0,240
<b>1500</b>	1,067	0,844	0,628	0,554	0,469	0,429	0,391	0,336	0,294	0,262	0,238
<b>1600</b>	1,062	0,840	0,610	0,551	0,450	0,420	0,389	0,334	0,293	0,260	0,237

	<b>B</b>										
<b>A</b>	<b>550</b>	<b>560</b>	<b>600</b>	<b>630</b>	<b>650</b>	<b>700</b>	<b>710</b>	<b>750</b>	<b>800</b>	<b>900</b>	<b>1000</b>
<b>180</b>	0,418	0,400	0,378	0,369	0,352	0,349	0,343	0,331	0,322	0,304	0,291
<b>200</b>	0,389	0,373	0,356	0,344	0,332	0,325	0,320	0,309	0,300	0,284	0,271
<b>225</b>	0,375	0,361	0,342	0,333	0,319	0,313	0,309	0,302	0,292	0,272	0,262
<b>250</b>	0,362	0,345	0,331	0,321	0,308	0,302	0,297	0,291	0,281	0,263	0,253
<b>280</b>	0,342	0,325	0,312	0,302	0,291	0,288	0,283	0,271	0,267	0,249	0,241
<b>300</b>	0,321	0,312	0,296	0,287	0,279	0,273	0,269	0,256	0,251	0,236	0,228
<b>315</b>	0,305	0,297	0,282	0,274	0,267	0,259	0,254	0,246	0,238	0,225	0,215
<b>355</b>	0,296	0,284	0,271	0,262	0,251	0,248	0,243	0,234	0,228	0,215	0,205
<b>400</b>	0,281	0,273	0,265	0,252	0,243	0,237	0,234	0,226	0,219	0,207	0,197
<b>450</b>	0,271	0,264	0,255	0,243	0,237	0,231	0,226	0,219	0,211	0,199	0,190
<b>500</b>	0,269	0,257	0,244	0,236	0,228	0,223	0,219	0,212	0,205	0,194	0,185
<b>550</b>	0,262	0,254	0,239	0,225	0,217	0,211	0,208	0,209	0,202	0,191	0,182
<b>560</b>	0,259	0,250	0,231	0,230	0,221	0,210	0,208	0,206	0,200	0,189	0,180
<b>600</b>	0,256	0,248	0,229	0,228	0,218	0,209	0,207	0,202	0,197	0,186	0,178
<b>630</b>	0,253	0,244	0,228	0,225	0,215	0,209	0,207	0,199	0,195	0,184	0,176
<b>650</b>	0,248	0,242	0,226	0,222	0,213	0,208	0,206	0,197	0,193	0,182	0,174
<b>700</b>	0,244	0,241	0,225	0,221	0,212	0,207	0,205	0,196	0,192	0,181	0,173
<b>710</b>	0,242	0,239	0,224	0,220	0,211	0,205	0,204	0,195	0,191	0,180	0,172
<b>750</b>	0,240	0,236	0,220	0,218	0,209	0,203	0,202	0,194	0,189	0,178	0,170
<b>800</b>	0,239	0,234	0,217	0,215	0,206	0,201	0,200	0,192	0,187	0,176	0,168
<b>900</b>	0,234	0,230	0,215	0,212	0,200	0,198	0,196	0,189	0,184	0,173	0,165
<b>1000</b>	0,231	0,227	0,211	0,209	0,198	0,195	0,193	0,185	0,181	0,171	0,163
<b>1100</b>	0,229	0,224	0,208	0,206	0,196	0,194	0,191	0,182	0,179	0,168	0,161
<b>1250</b>	0,224	0,221	0,205	0,203	0,192	0,191	0,189	0,180	0,176	0,166	0,159
<b>1400</b>	0,221	0,219	0,203	0,201	0,189	0,188	0,187	0,178	0,175	0,165	0,157
<b>1500</b>	0,220	0,218	0,201	0,200	0,187	0,186	0,185	0,176	0,174	0,164	0,156
<b>1600</b>	0,220	0,216	0,200	0,199	0,187	0,186	0,185	0,175	0,173	0,163	0,155

## 9. Noise data

### 9.1. Level of acoustic output corrected with filter A.

$$L_{WA} = L_{W1} + 10 \log(S) + K_A$$

$L_{WA}$  [dB(A)] level of acoustic output corrected with filter A

$L_{W1}$  [dB] level of acoustic output  $L_{W1}$  related to the 1 m<sup>2</sup> section (see Tab. 9.3.1.)

$S$  [m<sup>2</sup>] duct cross section

$K_A$  [dB] correction to the weight filter A (viz Tab. 9.3.2.)

### 9.2. Level of acoustic output in octave ranges.

$$L_{Woct} = L_{W1} + 10 \log(S) + L_{rel}$$

$L_{Woct}$  [dB] spectrum of acoustic output in octave range

$L_{W1}$  [dB] level of acoustic output  $L_{W1}$  related to the 1 m<sup>2</sup> section (see Tab. 9.3.1.)

$S$  [m<sup>2</sup>] duct cross section

$L_{rel}$  [dB] relative level expressing the shape of the spectrum (see Tab. 9.3.3.)

### 9.3. Table of acoustics values

Tab. 9.3.1. Level of acoustic output  $L_{W1}$ [dB] related to the 1 m<sup>2</sup> section

$v$ [m/s]	[-] $\xi$														
	0,2	0,3	0,4	0,5	0,6	0,7	0,8	0,9	1	1,5	2	2,5	3	4	5
2	15,5	18,7	20,9	22,6	24	25,2	26,3	27,2	28	31,2	33,4	35,1	36,5	38,8	40,5
3	26,1	29,2	31,5	33,2	34,6	35,8	36,9	37,8	38,6	41,7	44	45,7	47,1	49,4	51,1
4	33,6	36,7	39	40,7	42,1	43,3	44,3	45,3	46,1	49,2	51,5	53,2	54,6	56,9	58,6
5	39,4	42,5	44,8	46,5	47,9	49,1	50,2	51,1	51,9	55	57,3	59	60,4	62,7	64,4
6	44,1	47,3	49,5	51,3	52,7	53,9	54,9	55,8	56,6	59,8	62	63,8	65,2	67,4	69,2
7	48,2	51,3	53,5	55,3	56,7	57,9	58,9	59,8	60,7	63,8	66,1	67,8	69,2	71,4	73,2
8	51,6	54,8	57	58,8	60,2	61,4	62,4	63,3	64,1	67,3	69,5	71,3	72,7	74,9	76,7
9	54,7	57,9	60,1	61,8	63,2	64,4	65,5	66,4	67,2	70,4	72,6	74,3	75,7	78	79,7
10	57,4	60,6	62,8	64,6	66	67,2	68,2	69,1	70	73,1	75,3	77,1	78,5	80,7	82,5
11	59,9	63,1	65,3	67,1	68,5	69,7	70,7	71,6	72,4	75,6	77,8	79,6	81	83,2	85
12	62,2	65,4	67,6	69,3	70,7	71,9	73	73,9	74,7	77,9	80,1	81,8	83,2	85,5	87,2

Tab. 9.3.2. Correction to the weight filter A

$w$ [m/s]	2	3	4	5	6	7	8	9	10	11	12
$K_A$ [dB]	-15,0	-11,8	-9,8	-8,4	-7,3	-6,4	-5,7	-5,0	-4,5	-4,0	-3,6

Tab. 9.3.3. Relative level expressing the shape of the spectrum  $L_{rel}$ 

w [m/s]	f [Hz]							
	63	125	250	500	1000	2000	4000	8000
2	-4,5	-6,9	-10,9	-16,7	-24,1	-33,2	-43,9	-56,4
3	-3,9	-5,3	-8,4	-13,1	-19,5	-27,6	-37,4	-48,9
4	-3,9	-4,5	-6,9	-10,9	-16,7	-24,1	-33,2	-43,9
5	-4,0	-4,1	-5,9	-9,4	-14,6	-21,5	-30	-40,3
6	-4,2	-3,9	-5,3	-8,4	-13,1	-19,5	-27,6	-37,4
7	-4,5	-3,9	-4,9	-7,5	-11,9	-17,9	-25,7	-35,1
8	-4,9	-3,9	-4,5	-6,9	-10,9	-16,7	-24,1	-33,2
9	-5,2	-3,9	-4,3	-6,4	-10,1	-15,6	-22,7	-31,5
10	-5,5	-4	-4,1	-5,9	-9,4	-14,6	-21,5	-30
11	-5,9	-4,1	-4	-5,6	-8,9	-13,8	-20,4	-28,8
12	-6,2	-4,3	-3,9	-5,3	-8,4	-13,1	-19,5	-27,6



## IV. MATERIAL, FINISHING

### 10. Material

- 10.1.** Damper bodies are supplied in the design made of galvanized plate without any other surface finishing.

Damper blades are made of fire resistant asbestos free boards made of mineral fibres.

Control devices of dampers has cover from mechanically resistant and standing plastic and rest of the parts is galvanized without further surface treatment.

Springs are galvanized.

Thermal protective fuses are made of sheet brass, thickness = 0.5 mm.

Fasteners is galvanized. Fasteners is galvanized.

- 10.2.** According to the customer's requirements, damper can be made of stainless material.

Specifications for stainless-steel models – classification of stainless steel:

- Class A2 – Food-grade stainless steel (AISI 304 – EN 17240)
- Class A4 – Chemistry-grade stainless steel (AISI 316, 316L – EN 17346, 17349)

The respective stainless steel is the material for all components present or accessing the damper interior; components outside the damper body are typically from galvanized sheet metal (fasteners for mounting the servo drive or mechanics, mechanics components except Item 4), frame components.

The following components, including the fasteners, are made from stainless steel at all times:

- 1) Damper body and all components permanently attached
- 2) Leaf holders, including pins, metal parts of leaf
- 3) Control components inside the damper (leaf angle selector, pin with lever)
- 4) Mechanical components entering the interior of damper body (lower sheet of mechanics, lock holder "1", lock lever "2", lock spring, 8 dia. stopper pin, mechanics pin)
- 5) Inspection hole cover including the clip and fasteners (if they are parts of the cover)
- 6) Bearing for torque transfer from the lever with pin on the angle selector at the leaf (made from AISI 440C)

The leaf of the damper is made from a single piece of homogeneous material Promatect-MST, thickness 40 mm or is composite from two piece Promatect-H, thickness 20 mm, connected with galvanized nailed "U" connectors which are sealed with Promat K84 from the outside.

Plastic, rubber and silicon components, sealants, foaming bands, glass-ceramic seals, housings, brass bearings of the leaf, servo drives, and end switches are identical for all material variants of the dampers.

The thermal link is identical for all material variants of the dampers. Upon specification by customer, the thermal link may be made from A4 from stainless steel sheet metal.

The temperature-dependent initiator of the servo drive (sensor) is modified for stainless-steel variants of the dampers; the standard galvanized screws are replaced with stainless-steel M4 screws of corresponding class the counterpart has stainless-steel riveting M4 nuts.

Some fasteners and components are available in one class of stainless steel; the type will be used in all stainless-steel variants.

The leaf in the variants for chemical environments (Class A4) is always treated with a coating of chemically resistant Promat SR.

Any other requirements for the design shall be considered atypical and shall be addressed on an individual basis.

**V. INSPECTION, TESTING**

**11. Inspection, testing**

- 11.1. The appliance is constructed and and preset by the manufacturer, its operation is dependent on proper installation and adjustment.

**VI. TRANSPORTATION AND STORAGE**

**12. Logistic terms**

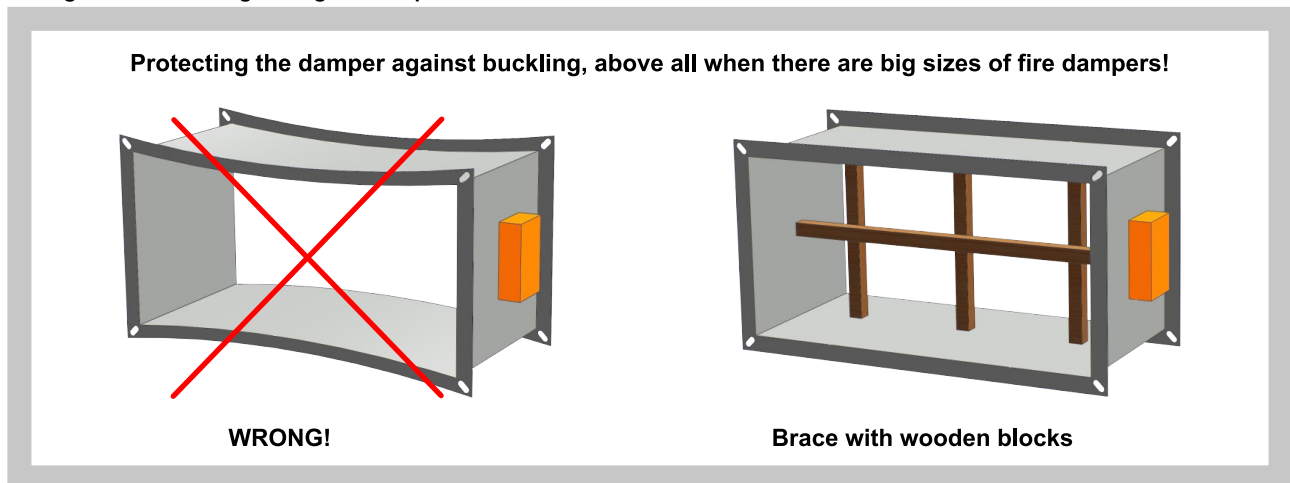
- 12.1. Dampers are transported by box freight vehicles without direct weather impact, there must not occur any sharp shocks and ambient temperature must not exceed +40°C. Dampers must be protected against mechanic damages when transported and manipulated. During transportation, the damper blade must be in the "CLOSED" position.
- 12.2. Dampers are stored indoor in environment without any aggressive vapours, gases or dust. Indoor temperature must be in the range from -30°C to +40°C and maximum relative humidity 95 % (avoid condensation on the damper body). Dampers must be protected against mechanic damages when transported and manipulated.

**VII. ASSEMBLY, ATTENDANCE, MAINTENANCE AND REVISIONS**

**13. Assembly**

- 13.1. All effective safety standards and directives must be observed during fire damper assembly.
- 13.2. The damper body should not be deformed in the course of bricking in. Once the damper is built in, its blade should not grind on the damper body during opening or closing.

Fig. 53 Embedding / fixing the damper



- 13.3. Flange and screw joints must be conductively connected to protect against dangerous contact. 2 galvanized fan shape pads that are placed under the head of one screw and a fastened nut are used for conductive connection.
- 13.4. To ensure reliable fire damper function it is necessary to avoid blocking the closing mechanism and contact surfaces with collected dust, fibre and sticky materials and solvents.
- 13.5. Manual operation  
Without power supply, the damper can be operated manually and fixed in any required position. Release of the locking mechanism can be achieved manually or automatically by applying the supply voltage.

## 14. Entry into service and revisions

- 14.1.** Before entering the dampers into operation after assembly and after sequential revisions, checks and functionality tests of all designs including operation of the electrical components must be done. After entering into operation, these revisions must be done according to requirement set by national regulations.

In case that dampers are found unable to serve for their function for any cause, it must be clearly marked. The operator is obliged to ensure so that the damper is put into condition in which it is able to function and meanwhile he is obliged to provide the fire protection another appropriate way.

Results of regular checks, imperfections found and all-important facts connected with the damper function must be recorded in the "FIRE BOOK" and immediately reported to the operator.

- 14.2.** Before entering the dampers into operation after their assembly and by sequential checks, the following checks must be carried out for all designs.

Visual inspection of proper damper integration, inside damper area, damper blade, contact surfaces and silicon sealing.

Inspection hole disassembly: release the covering lid by turning the wing nut and while turning the lid right or left release it from the security belt. Then tilt the lid and remove it from its original position.

- 14.3.** Before entering the dampers with manual control into operation after their assembly and by sequential checks and following checks must be carried out.

Check of thermal protective fuse and closing mechanism.

Exert pressure on double arm initiation lever with a spring to release the control lever and check its displacement into the "CLOSED" position. Closing must be smart and the control lever must be firmly locked with a pawl. In case that the closing is not smart enough and the control lever is not locked with the pawl in the "CLOSED" position, higher pre-stretch of the closing spring must be set using a ratchet wheel.

Proper function of the thermal fuse can be checked when the fuse is removed from the starting mechanism pin. The pin must be taken out and the initiation lever must be turned over. If this is not possible, then the pin and the starting mechanism spring must be checked or the base plate must be replaced. The base plate is attached to the damper body with three M5 screws and nuts.

Displacing the damper blade into "OPEN" position is done the following way:

Release the pawl exerting pressure and return the control lever into the second outlying position where the lever is hold by the initiation lever.

In case of the flap valve with an electromagnet check the control lever displacement into the "CLOSED" position after connecting to power supply.

- 14.4.** Before entering the dampers with actuating mechanism into operation after their assembly and by sequential checks and following checks must be carried out.

Check of blade displacement into the breakdown position "CLOSED" can be done after cutting off the actuating mechanism supply (e.g. by pressing the RESET button at the thermoelectrical starting mechanism BAT72B-S or cutting off the supply from ELECTRICAL FIRE SIGNALISATION). Check of blade displacement back into the "OPEN" position can be done after restoration of power supply (e.g. By releasing the RESET button or restoration of supply from ELECTRICAL FIRE SIGNALISATION).

- 14.5.** Dampers could be displaced into position "CLOSED" only in case that ventilator, or Air Handling Unit is switched off. The goal is the securing of proper closing and safe function of Fire Damper in case of Fire.

## 15. Spare parts

- 15.1.** Spare parts are supplied only on basis of an order.

## 16. Restore function of actuating mechanism after fuses initiation

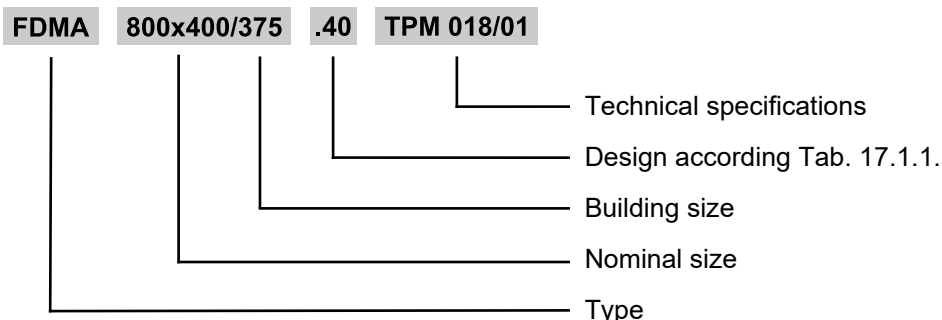
- 16.1.** If fuse Tf1 is initiated (duct outside temperature) than is necessary to change thermoelectrical starting mechanism BAT72B-S. Whereas is initiation temperature higher than actuator mechanism operating temperature +50°C, recommended actuating mechanism manufacturer make complete revision or change actuating mechanism and thermoelectrical starting mechanism.

- 16.2.** If fuses Tf2/Tf3 are initiated (duct inside temperature) than is possible change only part ZBAT72 or ZBAT95 (according initiating temperature).

**VIII. ORDERING INFORMATION**

**17. Ordering key**

**17.1. Fire damper**

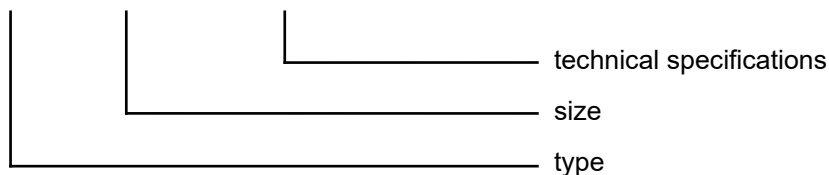


**Tab. 17.1.1. Dampers design**

Dampers design	Additional digit
Manual and thermal	.01
Manual and thermal (ZONE 1, 2)	.02
Manual and thermal with a terminal switch („CLOSED“)	.11
Manual and thermal with a terminal switch („CLOSED“) (ZONE 1, 2)	.12
Manual, thermal and with an electromagnet AC 230 V	.20
Manual, thermal and with an electromagnet AC/DC 24 V	.21
Manual, thermal and with an electromagnet AC 230 V, with a terminal switch („CLOSED“)	.23
Manual, thermal and with an electromagnet AC/DC 24 V, with a terminal switch („CLOSED“)	.24
Manual, thermal and with an electromagnet AC 230 V (ZONE 2 )	.30
Manua, thermal and with an electromagnet AC 230 V, with a terminal switch („CLOSED“) (ZONE 2)	.33
With actuating mechanism BF 230-TN (BFL, BFN 230-T)	.40
With actuating mechanism BF 24-TN (BFL, BFN 24-T) , with smoke detector ORS 142 K and with supply device BKN 230-24-MOD (voltage AC 230 V)	.41
With actuating mechanism ExMax-15-BF (AC 230 V, AC/DC 24 V) with thermoelectrical starting mechanism (ZONE 1,2)	.42
With actuating mechanism BF 24-TN (BFL, BFN 24-T)	.50
With actuating mechanism BF 24-TN (BFL, BFN 24-T), with smoke detector ORS 142 K (voltage AC/DC 24 V)	.51
With communication and supply device BKN 230-24-MOD, with actuating mechanism BF 24-TN-ST (BFL, BFN 24-T-ST) and with smoke detector ORS 142 K	.63
Manual and thermal with two terminal switches („OPEN“, „CLOSED“)	.80
Manual and thermal with two terminal switches („OPEN“, „CLOSED“) (ZONE 1,2)	.81
Manual, thermal and with an electromagnet AC 230 V, with two terminal switches („OPEN“, „CLOSED“)	.82
Manual, thermal and with an electromagnet AC/DC 24 V., with two terminal switches („OPEN“, „CLOSED“)	.83
Manual, thermal and with an electromagnet AC 230 V, with two terminal switches („OPEN“, „CLOSED“) (ZONE 2)	.85

17.2. Reinforcement - damper placement outside wall or ceiling construction

**VRM-Q 800x400 TPM 018/01**

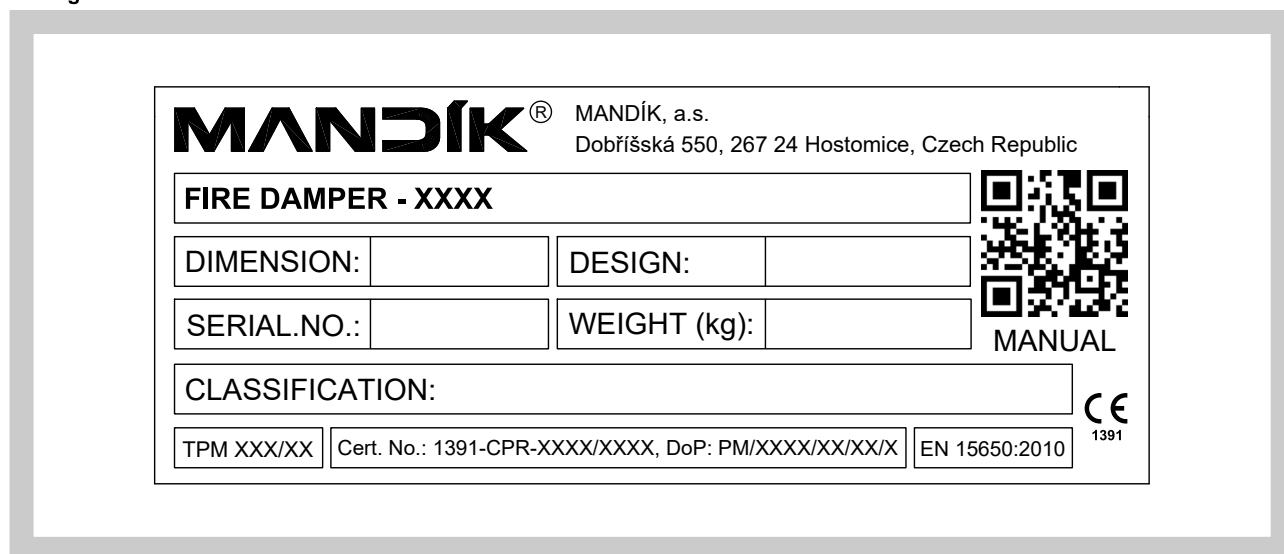


**IX. PRODUCT DATA**

**18. Data label**

18.1. Data label is placed on the damper body.

Fig. 54 Data label



MANDÍK, a.s.  
 Dobříšská 550  
 26724 Hostomice  
 Czech Republic  
 Tel.: +420 311 706 706  
 E-Mail: mandik@mandik.cz  
 www.mandik.com

The producer reserves the right for innovations of the product. For actual product information see [www.mandik.com](http://www.mandik.com)