

EN 12101-8

MANDÍK[®]

SINGLE COMPARTMENT SMOKE CONTROL DAMPER

SEDS-R

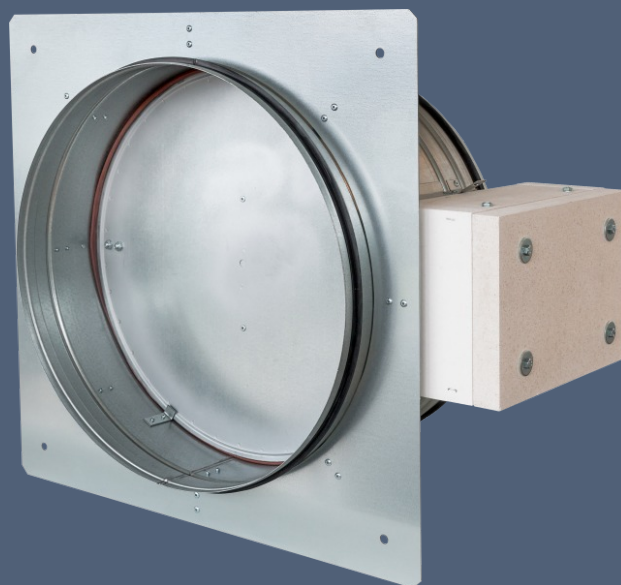

These technical specifications state a row of manufactured sizes and models of round Single compartment smoke control damper (further only dampers) SEDS-R. It is valid for production, designing, ordering, delivery, maintenance and operation.

I. CONTENT

II. GENERAL INFORMATION	3
1. Description.....	3
2. Design.....	4
3. Dimensions, weights.....	9
4. Placement and Assembly.....	10
5. Suspension systems.....	12
III. TECHNICAL DATA	13
6. Pressure loss.....	13
7. Coefficient of local pressure loss.....	13
8. Noise data and pressure loses.....	14
IV. MATERIAL, FINISHING	15
9. Material.....	15
V. INSPECTION, TESTING	15
10. Inspection, testing.....	15
VI. TRANSPORTATION AND STORAGE	15
11. Logistic terms.....	15
VII. ASSEMBLY, ATTENDANCE, MAINTENANCE AND REVISIONS	15
12. Assembly.....	15
13. Entry into service and revisions.....	17
14. Spare parts.....	17
VIII. PRODUCT DATA	18
15. Product label.....	18
IX. ORDERING INFORMATION	18
16. Ordering key.....	18

II. GENERAL INFORMATION

1. Description

- 1.1. Single compartment smoke control damper are shutters in smoke exhaust duct systems. Dampers are designed to remove heat and combustion products (e.g. smoke) from single fire compartment. In the event of fire the Smoke and Fire ventilation system opens the damper in the affected section which removes combustion products and heat from this section.

The damper blade is operated by an actuating mechanism.

The dampers can be installed in various duct sizes with respect to the field of direct applications according with EN 1366-9.

The field of direct applications based on tests results is acceptable according to EN 1363-1, part A.1 and A.2, EN 1366-2, part 13 and EN 1366-10, part 9.

Round smoke control dampers only for duct installation - single are classified as

E₆₀₀ 120 (v_{e-i}↔o) S1500C_{mod}MA_{single}

The duct can be ended by KMM (TPM 002/96) grilles. During grilles installation blade overlaps has to be respected see chapter 3.3.

Fig. 1 Damper SEDS-R



1.2. Damper characteristics

- CE certified acc. to EN 12101-8
- Tested in accordance with EN 1366-10
- Classified acc. to EN 13501-4
- External Casing leakage min. class B, Over blade min. class 4, diameter 100 min. class 3
- Cycling test in class C_{mod} acc. to EN 12101-8
- ES Certificate No. 1391-CPR-2020/0188
- Declaration of Performance No. PM/SEDS-R/01/22/1
- Hygienic assessment of smoke control dampers - Report No. 1.6/pos/19/19c

1.3. Working conditions

Dampers are designed for smoke exhaust duct systems with underpressure max. 1500 Pa or overpressure max. 500 Pa.

Dampers are designed for maximum air velocity 15 m/s.

Dampers are designed for installation with horizontal blade axis. Flow direction has to be led from actuating side (it is labeled by arrow on the damper casing).

Dampers are suitable for systems without abrasive, chemical and adhesive particles.

Dampers are designed for macroclimatic areas with mild climate according to EN 60 72133.

Temperature in the place of installation is permitted to range from -30°C to +50°C.

2. Design

2.1. Design with actuating mechanism

Design .44 and .54

Belimo actuators are used for dampers, series BEN for 230V AC resp. 24 V AC/DC.

After connection to the power supply voltage, the actuator moves the damper blade to the "OPEN" position or "CLOSED" (according to the corresponding connection, see wiring diagram). If the power supply is interrupted, the actuator stops at the current position. The signalling of the "OPEN" and "CLOSED" damper blade positions is ensured by two built-in fixed "potential-free" end-limit switches.

The actuator for operating the damper blade is mounted in an insulated cover/box. It is accessible after removing the cover lid. The electrical connection of the actuator is made with a non-flammable cable (or a cable located in the adjoining cable duct), which passes through an opening made in the wall of the insulated cover/box when installing the damper or when connecting the actuator power cable. The cable entry must meet a minimum fire resistance of 30 minutes.

Design .65

Belimo modulating actuators, BEN-SR series for 24V AC/DC are specially designed for remote control of smoke control dampers. The position of the damper blade is adjustable by means of control voltage 0 (2)...10V DC.

The signalling of the "OPEN" and "CLOSED" damper blade positions is ensured by two built-in fixed "potential-free" limit switches.

The actuator for operating the damper blade is mounted in an insulated cover/box. It is accessible after removing the cover lid. The electrical connection of the actuator is made with non-flammable cables (or cables located in the adjoining cable duct), which pass through an opening made in the wall of the insulated cover when installing the damper or when connecting the power cables of the actuator. The cable entry must meet a minimum fire resistance of 30 minutes.

Fig. 2 Damper SEDS-R - actuating mechanism

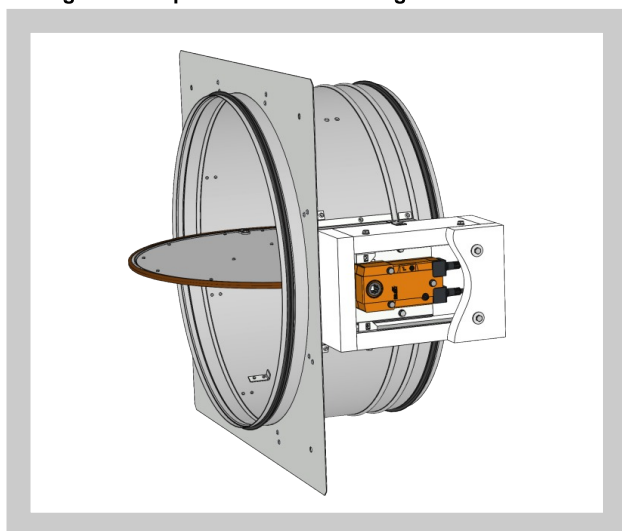

Tab. 2.1.1. Actuator BELIMO BEN 24(-ST), BEN 24-SR, BEN 230

Actuator BELIMO - 15 Nm	BEN 24(-ST)	BEN 24-SR	BEN 230
Power voltage	AC/DC 24 V 50/60Hz	AC/DC 24 V 50/60Hz	AC 230 V 50/60Hz
Power consumption - in operation - in the end position	3 W 0,1 W	3 W 0,3 W	4 W 0,4 W
Dimensioning	6 VA (Imax 8,2 A @ 5 ms)	6,5 VA (Imax 8,2 A @ 5 ms)	7 VA (Imax 4 A @ 5 ms)
Protection class	III	III	II
Degree of protection	IP 54		
Adjustment time for 95°	< 30 s		
Ambient temperature Storage temperature	-30°C ... +55°C -40°C ... +80°C		
Connection - drive - auxiliary switch	Cable 1 m, 3 x 0,75 mm ² Cable 1 m, 6 x 0,75 mm ² (BEN 24-ST) with plug connectors	Cable 1 m, 4 x 0,75 mm ² Cable 1 m, 6 x 0,75 mm ²	Cable 1 m, 3 x 0,75 mm ² Cable 1 m, 6 x 0,75 mm ²

Fig. 3 Actuator BELIMO BEN 24(-ST)

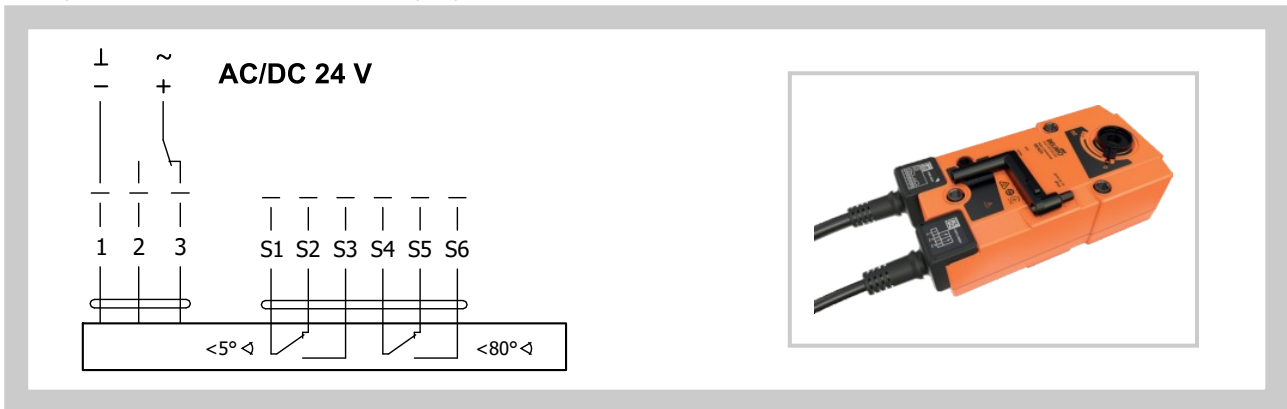

Fig. 4 Actuator BELIMO BEN 24-SR

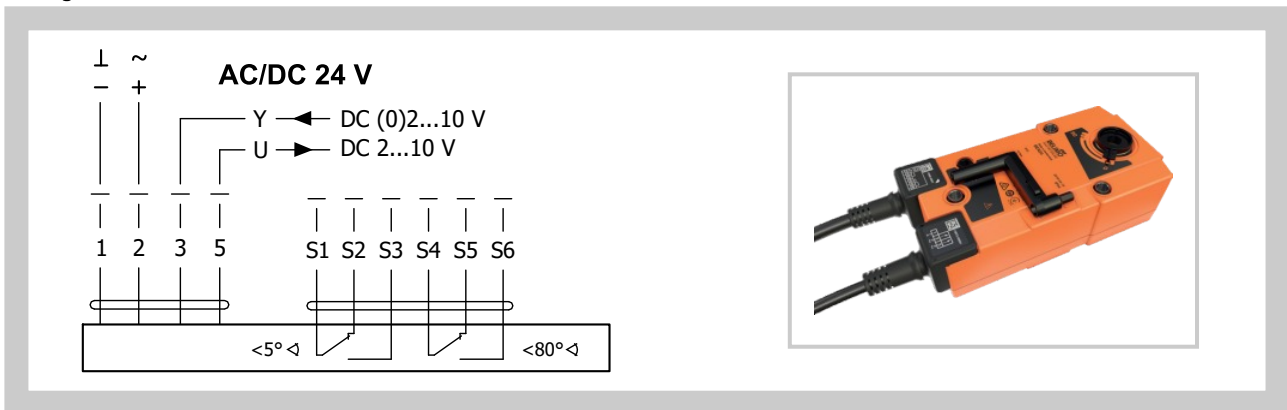
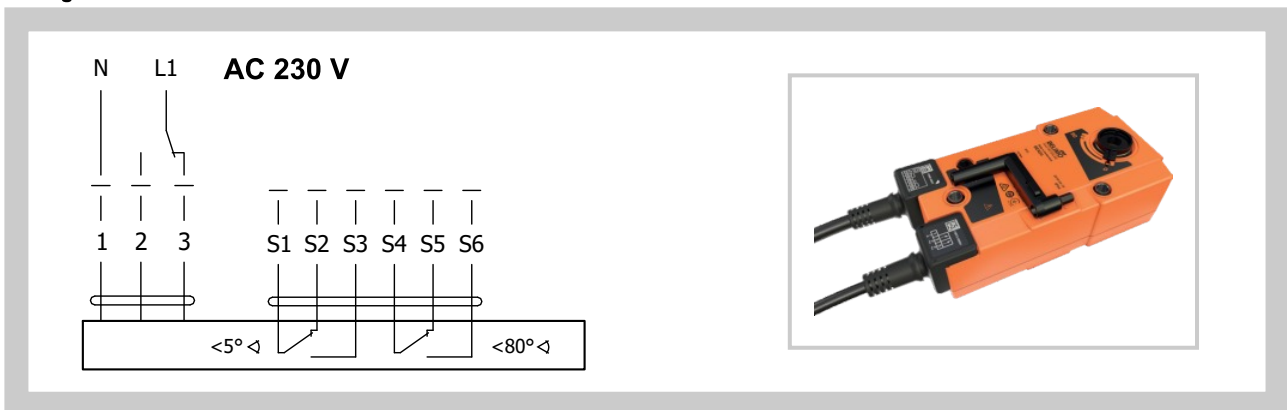

Fig. 5 Actuator BELIMO BEN 230



2.2. Design with the communication and power supply unit

Design .66

Design with communication and power supply device BKNE 230-24 and with actuator BEN 24-ST.

The BKNE 230-24 serves on the one hand as a decentralized network device for powering the actuator and on the other hand transmits the signal of the communication and control device BKSE 24-6.

It simplifies electrical installation and connection of dampers. In the meantime, it facilitates "on-site inspection" and allows central control and inspection of dampers using a simple 2-wire line.

The BKNE 230-24 transmits the "OPEN" / "CLOSED" damper position (switches in the actuator) and fault messages to the BKSE 24-6. It also receives commands from the control device and controls the adjustment of the actuator to the desired position. The last control command will be retained even after a temporary network failure..

The BKNE 230-24 controls the switching position of the actuator, its adjustment time and the data exchange with the BKSE 24-6. In addition, it controls the actuator current (actuator connection) and the power supply.

To simplify the connection, the actuator is equipped with plug connectors that plug directly into the BKNE 230-24.

The actuator, communication and power supply device BKNE 230-24 are mounted in an insulated cover, they are accessible after removing the cover. The electrical connection of the actuator and the BKNE 230-24 communication and power supply device is made with a non-flammable cable (or a cable located in an adjoining cable duct), the two-wire BKNE 230-24 cable should be connected to terminals 6 and 7. It is also recommended to use cable, which is used for fire signalling network. The cables pass through an opening made in the wall of the insulated cover when installing the damper or when connecting the actuator power cable. The cable entry must meet a minimum fire resistance of 30 minutes.

For more information on actuators and devices, see the Belimo catalogue.

Fig. 6 Damper SEDS-R - actuating mechanism and BKNE

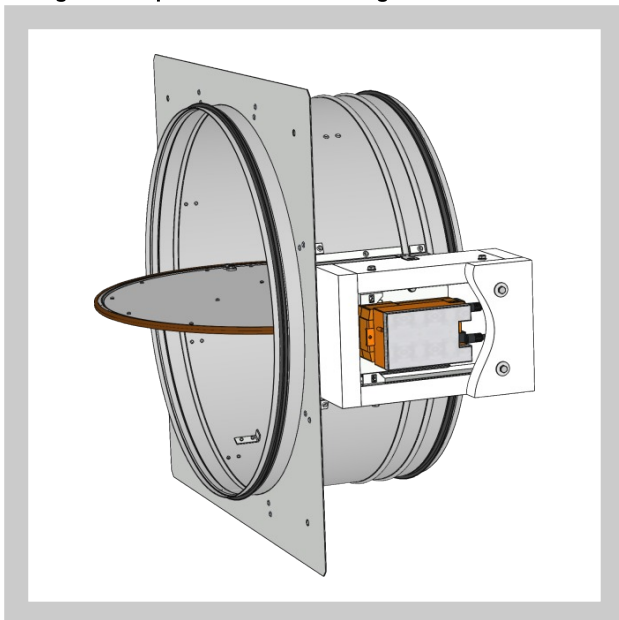

2.3. Communication and supply device

Tab. 2.3.1. Communication and power supply device BKNE 230-24

Communication and power supply device	BKNE 230-24
Power voltage	AC 230V 50/60Hz
Power consumption	10 W (including actuator)
Dimensioning	19 VA (including actuator)
Protection class	II
Ambient operation temperature	-30°C ... +50°C
Storage temperature	-40°C ... +80°C
Connection - network - drive - terminal blocks	cable 1 m without plug 6-pin plug, 3-pin plug screw terminals for 2x1.5 mm ² conductor

Fig. 7 Communication and power supply device BKNE 230-24

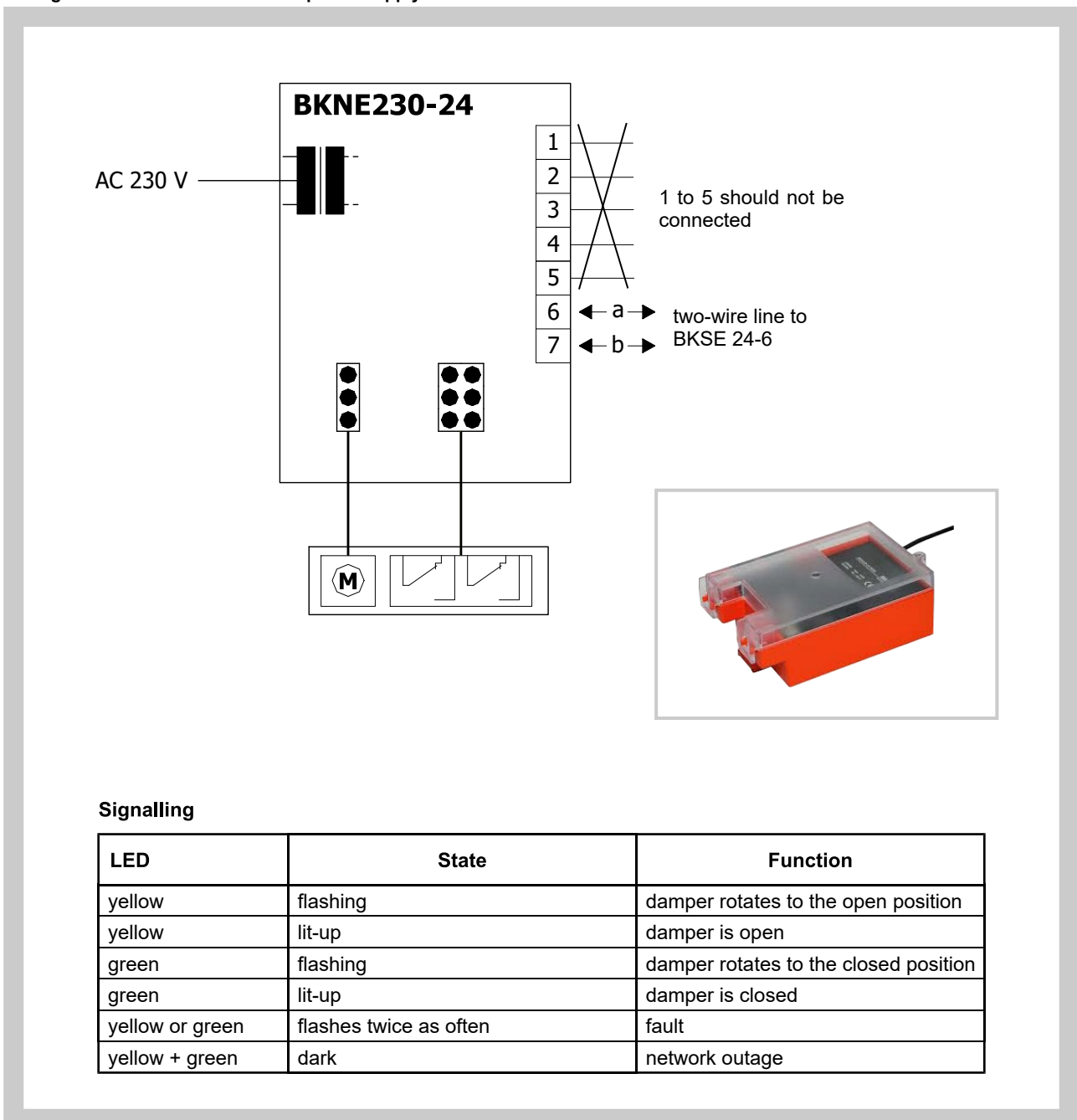

2.4. Communication and control devices

BKSE 24-6 indicates operating condition and faults of flue dampers. These conditions can be signalled or transmitted to the higher-level control system via the auxiliary built-in contacts. Signals from individual BKNE 230-24 are evaluated separately. All BKNE 230-24 are controlled simultaneously. A maximum of 6 BKNE 230-24 can be connected to the BKSE 24-6.

Damper control is ensured with a simple 2-wire line. The damper's correct function is indicated by two LEDs. The operating status of the entire control system and any errors are indicated by these LEDs and the corresponding error LED.

Mounting and connection of BKSE 24-6 can be done on a 35mm DIN rail. It's connected using two 9-pin terminal blocks (plug connectors).

Tab. 2.4.1. Communication and control devices BKSE 24-6

Communication and control devices	BKSE 24-6
Power voltage	AC 24 V 50/60Hz
Power consumption	3,5 W (operating position)
Dimensioning	5,5 VA 18 VA (I _{max} 6.4 A @ 2.5 ms)
Protection class	III (low voltage)
Degree of protection	IP 20
Ambient operation temperature	0 ... +50°C
Connection	screw terminals for 2x1.5 mm ² conductor

Fig. 8 Communication and control devices BKSE 24-6

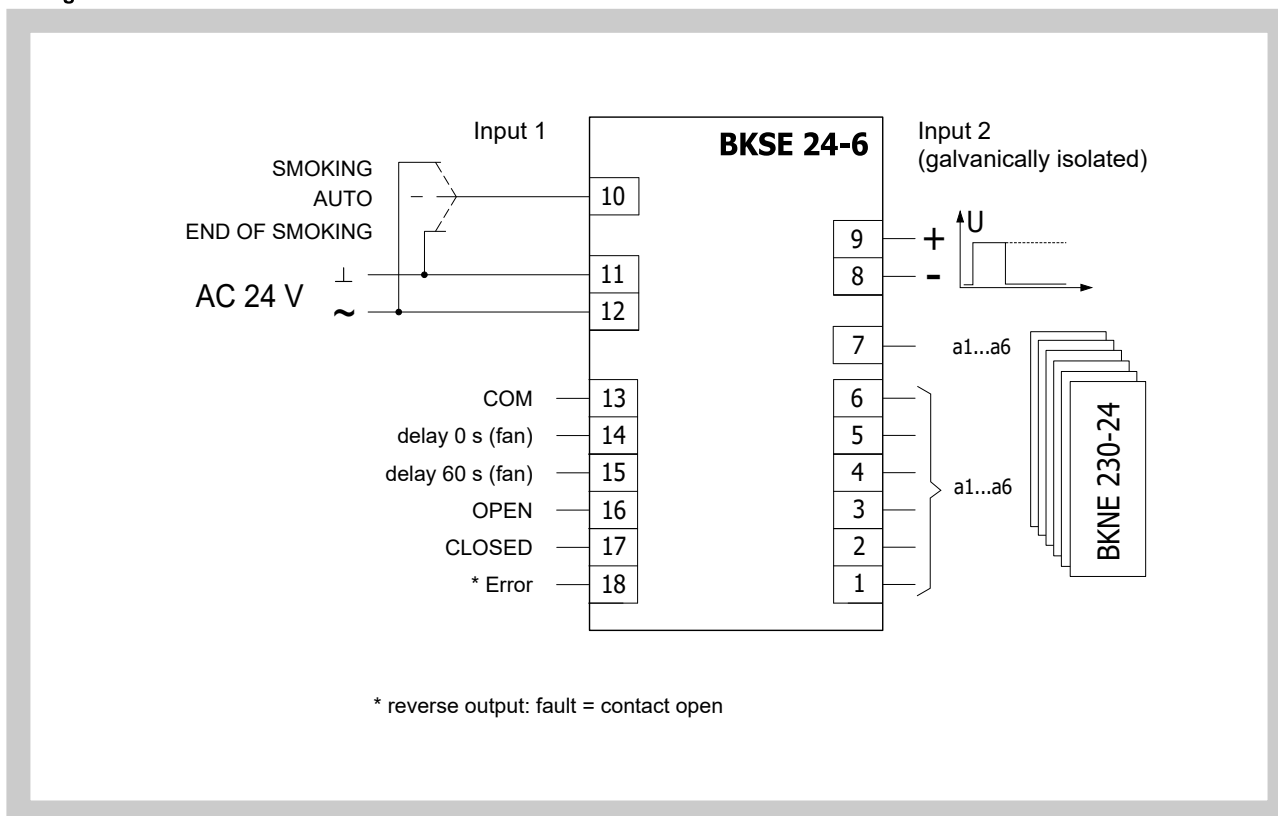

3. Dimensions, weights

3.1. Dimensions

Fig. 9 Damper SEDS-R

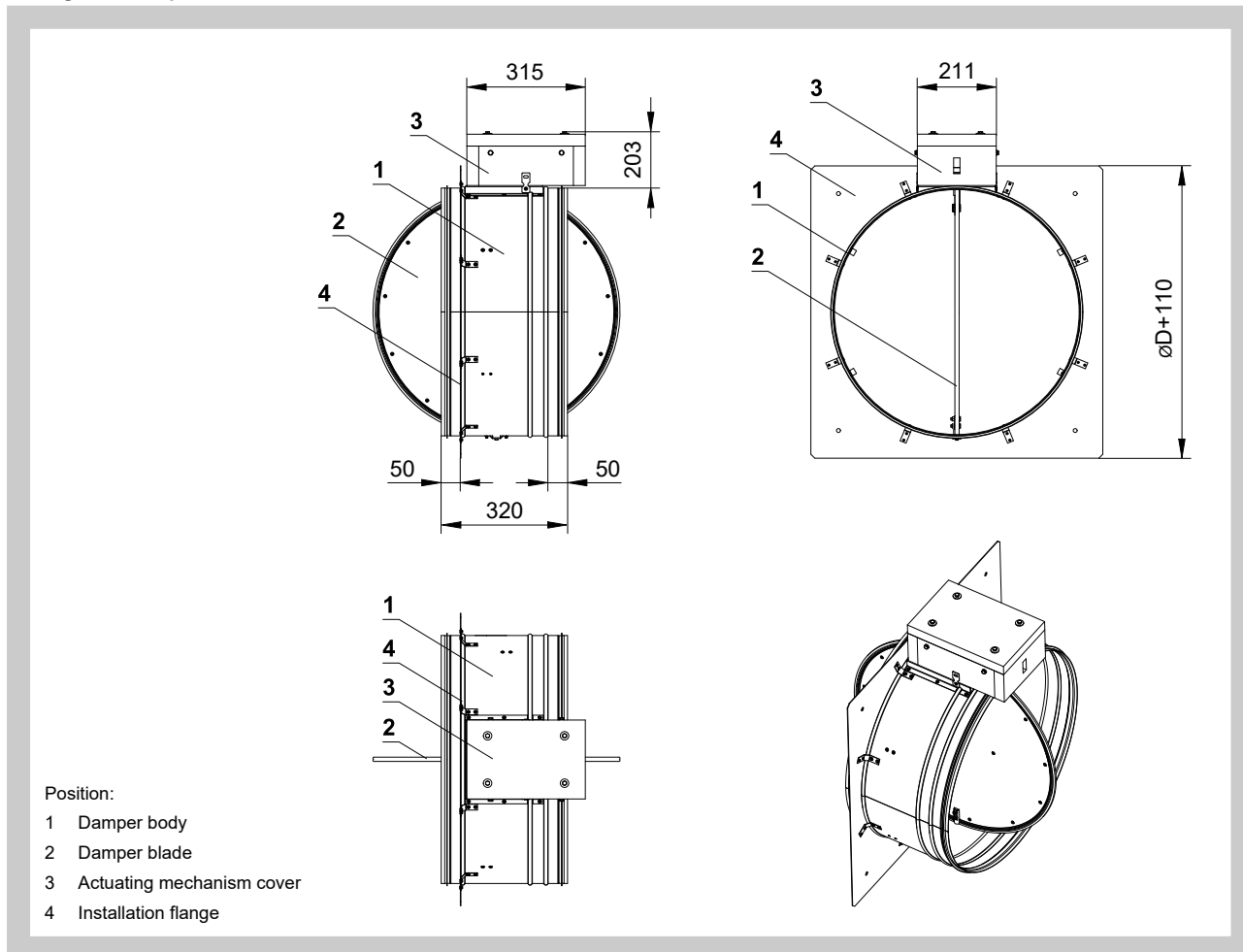

3.2. Weights and effective area

Tab. 3.2.1. Weights and effective area

Size $\varnothing D$	a	c	Weight [kg]	Effective area S_{ef} [m ²]	Actuating mechanism
100	-	-	10	0,0061	BELIMO BEN (15 N.m)
125	-	-	10,5	0,0100	BELIMO BEN (15 N.m)
160	-	-	11	0,0172	BELIMO BEN (15 N.m)
180	-	-	11,5	0,0222	BELIMO BEN (15 N.m)
200	-	-	12	0,0278	BELIMO BEN (15 N.m)
250	-	-	13	0,0446	BELIMO BEN (15 N.m)
280	-	-	13,5	0,0565	BELIMO BEN (15 N.m)
315	15,5	-	14,5	0,0722	BELIMO BEN (15 N.m)
355	35,5	-	15,5	0,0925	BELIMO BEN (15 N.m)
400	58	18	16,5	0,1183	BELIMO BEN (15 N.m)
450	83	43	18	0,1508	BELIMO BEN (15 N.m)
500	108	68	19,5	0,1872	BELIMO BEN (15 N.m)
560	138	98	21,5	0,2360	BELIMO BEN (15 N.m)
630	173	133	24,5	0,3001	BELIMO BEN (15 N.m)

If is used the communication and supply device BKNE230-24, the weight is higher by 0,68 kg.

- 3.3. For damper (Fig. 10) the open damper blade overlaps the damper body from dimension D=315 by the value "a" or "a" and "c". These values are specified in the Tab. 3.2.1.

Values "a" and "c" has to be respected when projecting related smoke exhaust ducts.

Fig. 10 Value "a" and "c"

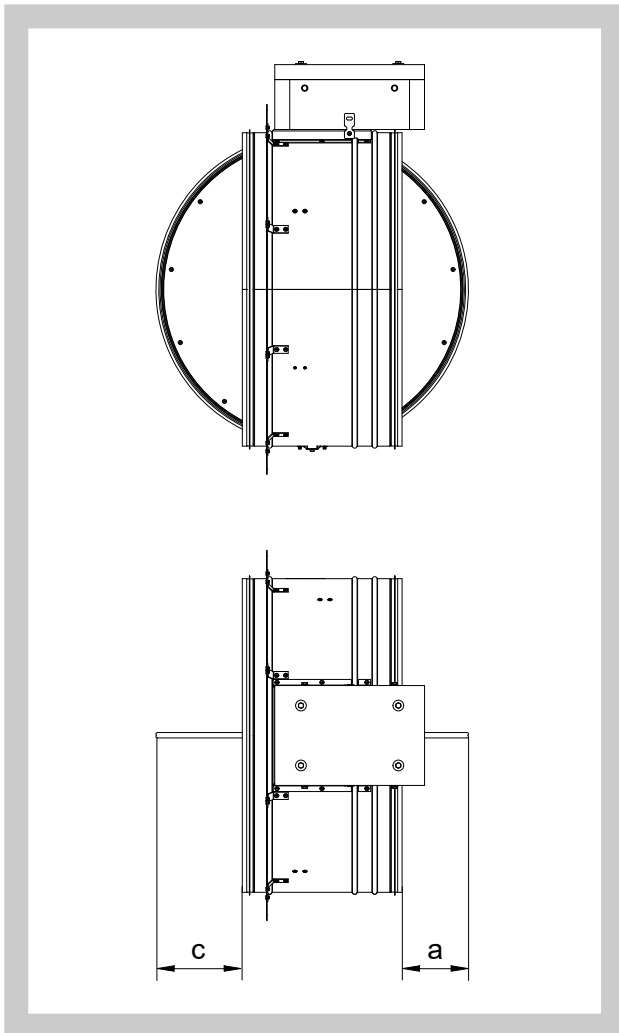

4. Placement and Assembly

- 4.1. Single compartment smoke control damper are designed to remove heat and combustion products (e.g. smoke) from single fire compartment according EN1366-9. Single compartment smoke control damper are designed for installation with horizontal blade axis. Backtoback smoke exhaust duct has to be hung or supported so as all load transfer from the backtoback smoke exhaust duct to the damper is absolutely excluded. To provide needed access space to the control device, all other objects must be situated at least 350 mm from the control parts of the damper.
- 4.2. During installation the damper blade must be in position CLOSED. The damper body should not be deformed in the course of installation. Once the damper built in, its blade should not grind on the damper body during opening or closing.

4.3. Installation examples

Fig. 11 Installation examples

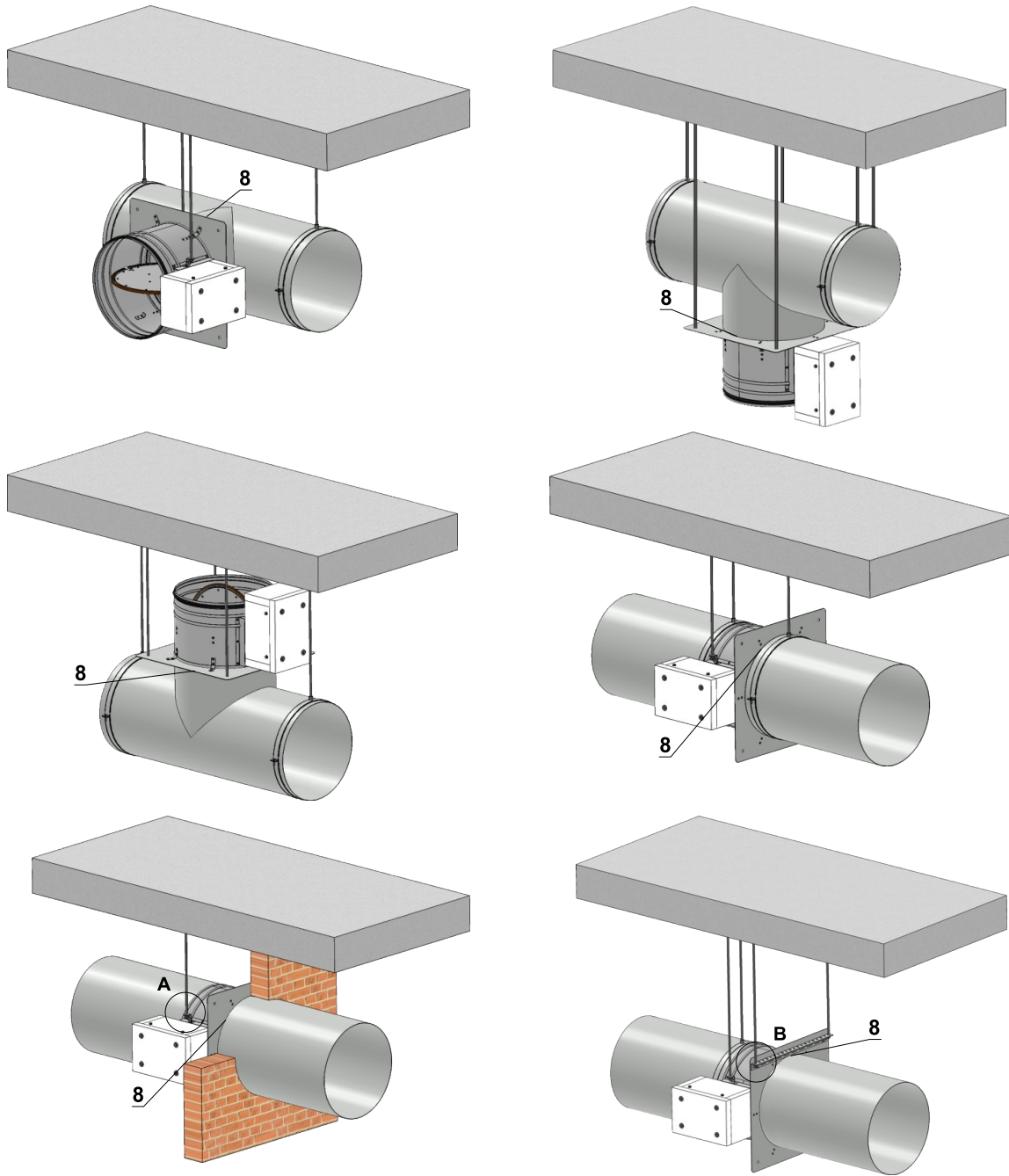

* Examples of fire sealants

- Hilti CFS-S ACR
- DenBraven FP403
- DenBraven Pyrocryl
- Promat Promaseal-AG
- Soudal Firecyl FR
- PROTECTA® FR ACRYLIC
- Soudal Firecyl FR
- Rockwool FIREPRO® High Expansion Intumescent Sealant
- ASTROFLAME PFP

Position:

- 1 Damper hinge
- 2 Holder L
- 3 Threaded rod
- 4 Washer
- 5 Nut
- 6 Screw connection
- 7 Profile 30x30
- 8 Connection between duct and damper, seal with fire sealant*

Detail A

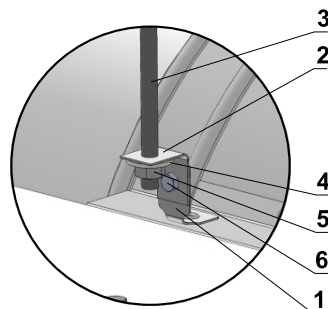

Detail B

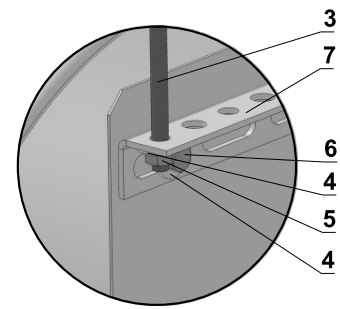

5. Suspension systems

5.1. Mounting to the ceiling wall

Fig. 12 Mounting to the ceiling wall

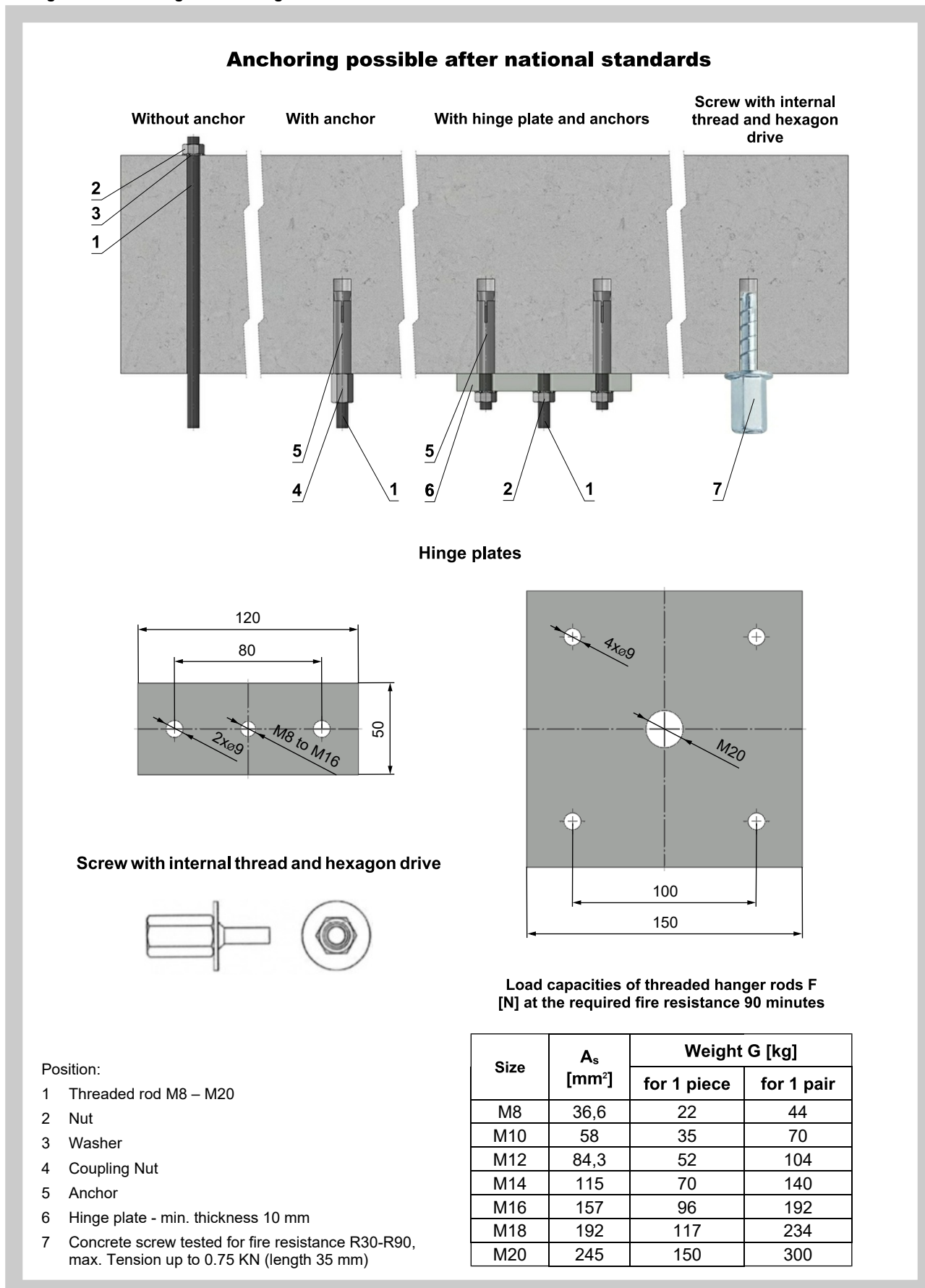

III. TECHNICAL DATA

6. Pressure loss

6.1. Pressure loss calculation

$$\Delta p = \xi \cdot \rho \cdot \frac{w^2}{2}$$

- Δp [Pa] pressure loss
- w [m.s⁻¹] air flow speed in nominal damper section
- ρ [kg.m⁻³] air density
- ξ [-] coefficient of local pressure loss for the nominal damper section (see Tab. 7.1.1.)

6.2. Determination of pressure loss by using diagram $\rho = 1,2 \text{ kg.m}^{-3}$

Diagram 6.2.1. Pressure losses for air density $\rho = 1,2 \text{ kg.m}^{-3}$

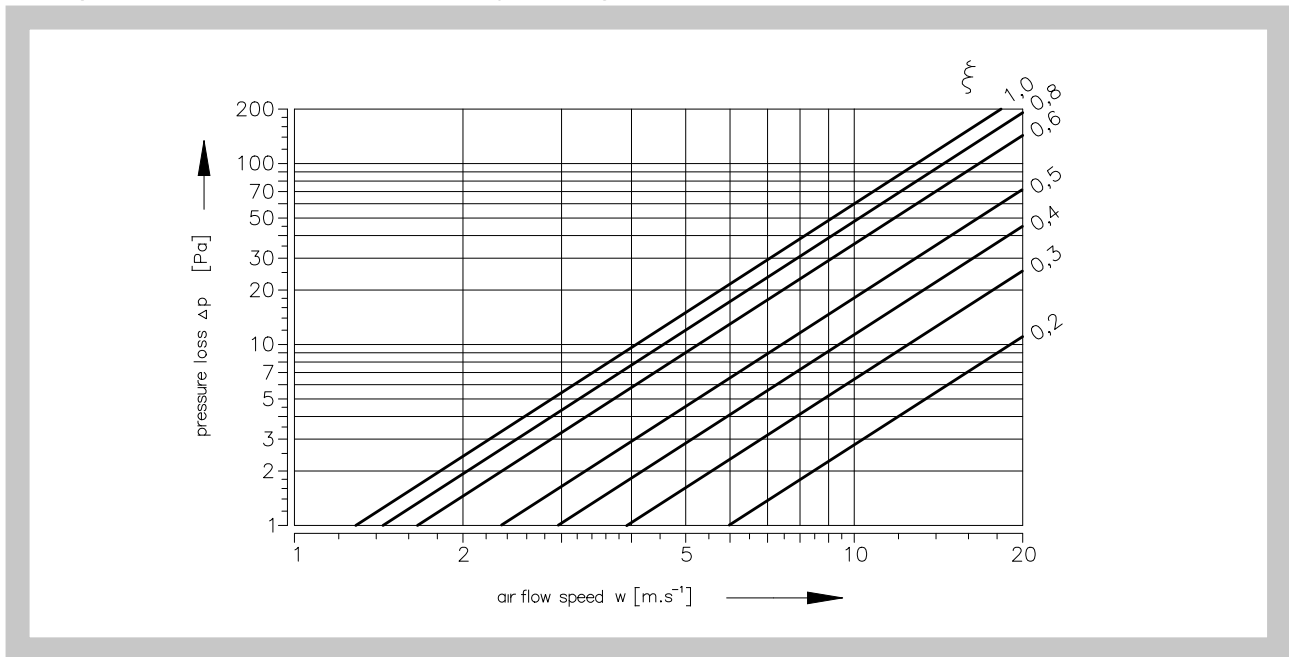

7. Coefficient of local pressure loss

7.1. Coefficient of local pressure loss ξ (-)

Tab. 7.1.1. Coefficient of local pressure loss

$\varnothing D$	100	125	160	180	200	250	280
ξ	1,111	0,930	0,760	0,649	0,576	0,500	0,424
$\varnothing D$	315	355	400	450	500	560	630
ξ	0,381	0,341	0,315	0,283	0,252	0,214	0,182

8. Noise data and pressure losses

Tab. 8.1.1. Noise data and pressure losses

Size		v [m.s ⁻¹]								Size		v [m.s ⁻¹]							
		3	4	5	6	7	8	9	10			3	4	5	6	7	8	9	10
100	\dot{V} [m ³ .h ⁻¹]	85	113	141	170	198	226	254	283	315	\dot{V} [m ³ .h ⁻¹]	842	1122	1403	1683	1964	2244	2525	2806
	L _{WA} [dB]	19	26	32	37	41	45	48	50		L _{WA} [dB]	6	13	19	24	28	31	34	37
	Δp [Pa]	6	11	17	24	33	43	54	67		Δp [Pa]	2	4	6	8	11	15	19	23
125	\dot{V} [m ³ .h ⁻¹]	133	177	221	265	309	353	398	442	355	\dot{V} [m ³ .h ⁻¹]	1069	1425	1782	2138	2494	2851	3207	3563
	L _{WA} [dB]	20	27	33	38	42	45	48	51		L _{WA} [dB]	6	13	19	24	28	32	35	37
	Δp [Pa]	5	9	14	20	27	36	45	56		Δp [Pa]	2	3	5	7	10	13	17	20
160	\dot{V} [m ³ .h ⁻¹]	217	290	362	434	507	579	651	724	400	\dot{V} [m ³ .h ⁻¹]	1357	1810	2262	2714	3167	3619	4072	4524
	L _{WA} [dB]	18	25	31	36	40	43	46	49		L _{WA} [dB]	6	14	20	24	28	32	35	38
	Δp [Pa]	4	7	11	16	22	29	37	46		Δp [Pa]	2	3	5	7	9	12	15	19
180	\dot{V} [m ³ .h ⁻¹]	275	366	458	550	641	733	824	916	450	\dot{V} [m ³ .h ⁻¹]	1716	2289	2861	3434	4006	4578	5150	5722
	L _{WA} [dB]	17	24	30	35	39	42	46	48		L _{WA} [dB]	5	13	19	23	27	31	34	37
	Δp [Pa]	4	6	10	14	19	25	32	39		Δp [Pa]	2	3	4	6	8	11	14	17
200	\dot{V} [m ³ .h ⁻¹]	339	452	565	679	792	905	1018	1131	500	\dot{V} [m ³ .h ⁻¹]	2121	2827	3534	4241	4948	5655	6362	7069
	L _{WA} [dB]	16	23	29	34	38	41	44	47		L _{WA} [dB]	4	12	18	22	26	30	33	36
	Δp [Pa]	3	6	9	12	17	22	28	35		Δp [Pa]	1	2	4	5	7	10	12	15
250	\dot{V} [m ³ .h ⁻¹]	530	707	884	1060	1237	1414	1590	1767	560	\dot{V} [m ³ .h ⁻¹]	2659	3545	4431	5317	6203	7090	7976	8862
	L _{WA} [dB]	12	20	26	30	34	38	41	44		L _{WA} [dB]	3	11	17	21	25	29	32	35
	Δp [Pa]	3	5	7	11	15	19	24	30		Δp [Pa]	1	2	3	5	6	8	10	13
280	\dot{V} [m ³ .h ⁻¹]	665	886	1108	1329	1551	1773	1994	2216	630	\dot{V} [m ³ .h ⁻¹]	3367	4489	5611	6733	7855	8978	10100	11222
	L _{WA} [dB]	8	17	22	29	32	35	36	39		L _{WA} [dB]	2	10	16	20	24	28	31	34
	Δp [Pa]	2	4	6	9	12	16	21	25		Δp [Pa]	1	2	3	4	5	7	9	11

IV. MATERIAL, FINISHING

9. Material

- 9.1. Damper casing and damper blade are made of galvanized plate without any other surface finish.
- 9.2. Fasteners are galvanized.

V. INSPECTION, TESTING

10. Inspection, testing

- 10.1. The appliance is constructed and preset by the manufacturer, its operation is dependent on proper installation and adjustment.

VI. TRANSPORTATION AND STORAGE

11. Logistic terms

- 11.1. Dampers are transported by box freight vehicles without direct weather impact, there must not occur any shocks and ambient temperature must not exceed +40°C. Dampers must be protected against mechanic damages when transported and manipulated. During transportation, the damper blade must be in the "CLOSED" position.
- 11.2. Dampers are stored indoor in environment without any aggressive vapours, gases or dust. Indoor temperature must be in the range from -30°C to +40°C and maximum relative humidity 95 % (avoid condensation on the damper body). Dampers must be protected against mechanic damages when transported and manipulated.

VII. ASSEMBLY, ATTENDANCE, MAINTENANCE AND REVISIONS

12. Assembly

- 12.1. Assembly, maintenance and damper function check can be done only by qualified and trained person, i.e. "AUTHORIZED PERSON" according to the manufacturer documentation. All works done on the smoke control dampers must be done according international and local norms and laws.
- 12.2. All effective safety standards and directives must be observed during damper assembly.
- 12.3. To ensure reliable smoke exhaust damper function it is necessary to avoid blocking the closing mechanism and contact surfaces with collected dust, fibre and sticky materials and solvents.
- 12.4. **Manual operation**
Without power supply, the damper can be operated manually and fixed in any required position.

12.5. Electrical connection of the actuator in protection box

Protection box without slot or predrilled holes

Drill two holes into the protection box (from outside to inside) and pull through field wiring cables (fire resistant cables) to connect actuator trailing lead. Protection box is made of calcium silicate plates.

Fig. 13 Example of position of holes in the wall of the box, without pre-manufactured slot

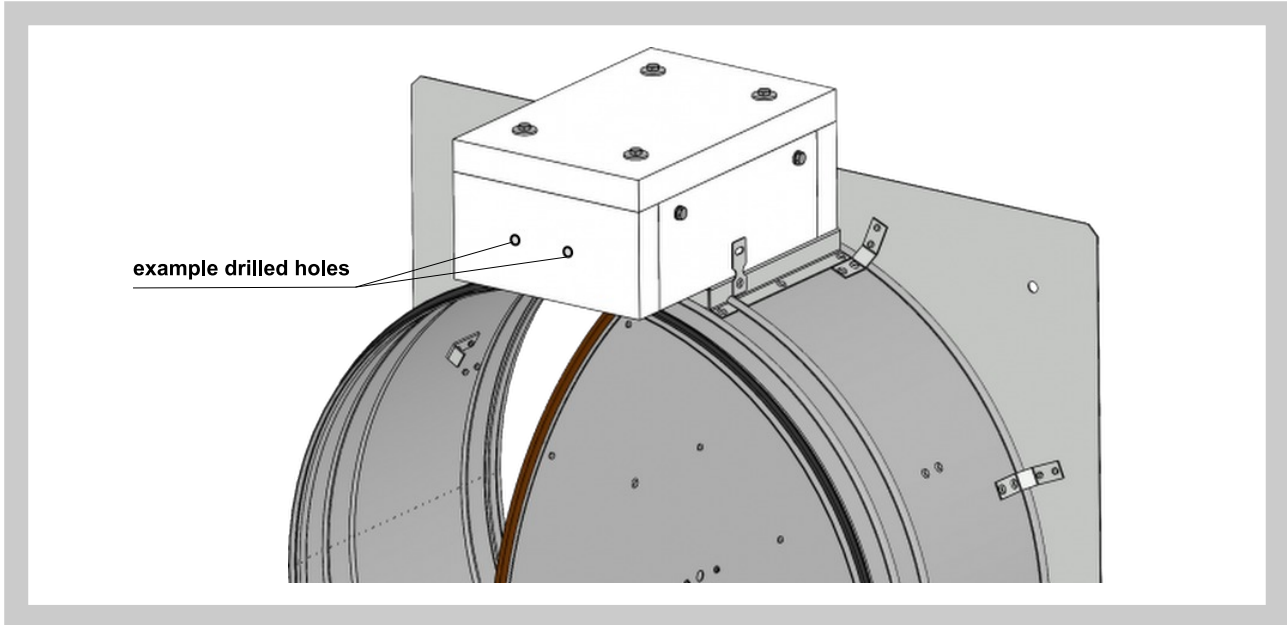

Procedure:

- Use drill (drill size acc. To suit connecting cable $\varnothing + 2$ mm for seal up by mastic) and make two holes (see fig. 13). **It is possible to drill holes in any side of the housing.**
- Pull the heat resistant cable through the calcium silicate plate (wall) and connect with cables from actuator acc. to above mentioned electrical diagram.
- Seal up the space around cable with fire resistant mastic (HILTI CFS-S ACR, PROMASTOP) or equivalent.
- Let the mastic harden.

Protection box with slot including intumescent tapes – not available for UK

Fig. 14 Example of pre-manufactured slot in the insulating box, with intumescent tape inside slot

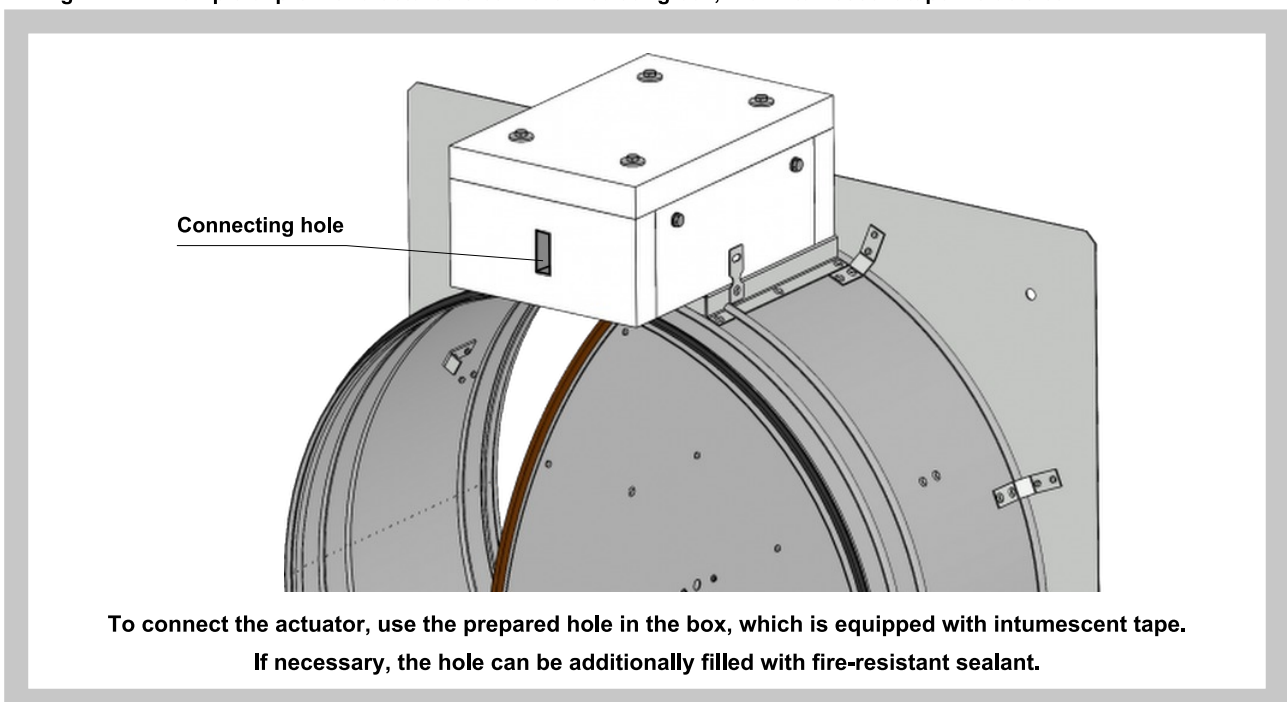

13. Entry into service and revisions

- 13.1.** Before entering the dampers into operation after assembly and after sequential revisions, checks and functionality tests of all designs including operation of the electrical components must be successfully provided and finished. After entering into operation, these revisions must be done according to requirement set by national regulations.
- 13.1.1.** In case that dampers are found unable to serve for their function for any cause, it must be clearly marked. The operator is obliged to ensure that the damper is put into condition in which it is ready for function and meanwhile he is obliged to provide the fire protection by another appropriate way.
- 13.1.2.** Results of regular checks, imperfections found and all-important facts connected with the damper function must be recorded in the "FIRE BOOK" and immediately reported to the operator.
- 13.2.** Before entering the dampers into operation after their assembly and by sequential checks, the following checks must be carried out for all designs.
- 13.2.1.** Visual inspection of proper damper integration, inside damper area, damper blade, contact surfaces and silicon sealing.
- 13.2.2.** Check of damper blade displacement can be realize after actuating mechanism supply connection or signal connection from higher level control systems. Blade displacement from position "OPEN" to position "CLOSED" and return displacement is checked.

14. Spare parts

- 14.1.** Spare parts are supplied only on basis of an order.

VIII. PRODUCT DATA

15. Product label

15.1. Product label is placed on the damper casing

Fig. 15 Product label (Nameplate)

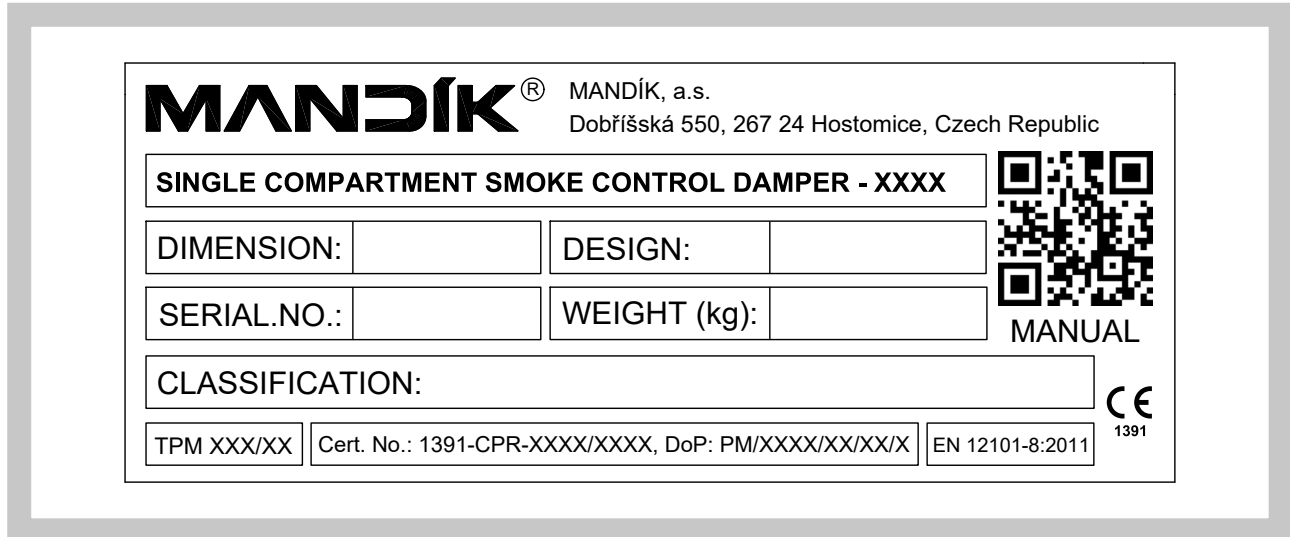

IX. ORDERING INFORMATION

16. Ordering key

SEDS-R 355 -.44 TPM 120/16

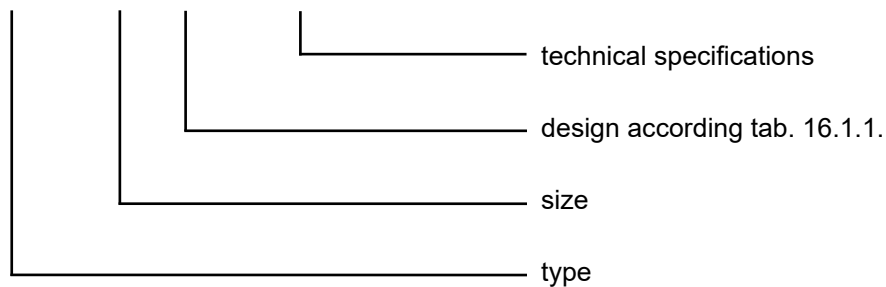

Tab. 16.1.1. Dampers design

Dampers design	Additional digit
with actuating mechanism BEN for 230V	.44
with actuating mechanism BEN for 24V	.54
with actuating mechanism BEN-SR for 24V	.65
with the communication and supply device BKNE 230-24 and actuating mechanism BEN-ST for 24V	.66

MANDÍK, a.s.
Dobříšská 550
26724 Hostomice
Czech Republic
Tel.: +420 311 706 706
E-Mail: mandik@mandik.cz
www.mandik.com

The producer reserves the right for innovations of the product. For actual product information see
www.mandik.com